

UNIT III

The Natural Phenomenon

Experiment 34

AIM

To verify the laws of reflection of light using a plane mirror.

THEORY

When light falls on a smooth polished surface, it gets reflected in a definite direction. Fig. 34.1 shows a ray of light PO, incident on a plane polished surface (plane mirror) SS'. Line OQ shows the changed path of the incident ray after reflection at the point O. The ray PO is called *incident ray* and ray OQ is called *reflected ray*. The point O where the incident ray strikes the polished surface is called *point of incidence*. If ON be the normal to the polished surface SS' at point O, then the angle PON and the angle NOQ are called the *angle of incidence* (i) and the *angle of reflection* (r) respectively. The plane containing the incident ray and normal is called *plane of incidence*.

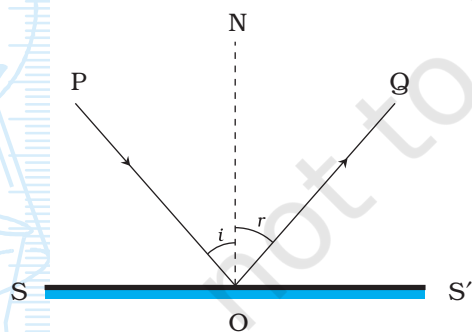

Fig. 34.1 : Reflection of a ray of light

The laws of reflection as deduced from the experiments states that the reflected ray lies in the plane of incidence along with the normal at the point of incidence, and $\angle i = \angle r$.

MATERIALS REQUIRED



A plane mirror with a support to hold it vertical, a drawing board, sheet of white paper, protractor, measuring scale, pins, drawing pins or adhesive tape.

PROCEDURE



1. Fix a white sheet of paper on the drawing board using either adhesive tape or drawing pins.
2. Draw a thin line SS' in the middle of the paper. Also draw a normal ON to the line SS' at point O as shown in Fig. 34.2.
3. Draw a thin line PO at any angle to the line SS' . Place the mirror vertically on line SS' with the help of a support so that its polished surface faces line PO .
4. Vertically fix two pins P_1 and P_2 with their tips, separated by a suitable distance of about 5 to 6 cm at two points on line PO . Look at the images P'_1 and P'_2 of pins P_1 and P_2 respectively from the same side of the plane mirror.
5. Fix two pins P_3 and P_4 , vertically such that their feet appear to be in the same straight line as that of images P'_1 and P'_2 . Look through the feet of pins P_1 and P_2 , whether the feet of images (not shown in the Fig. 34.2 of pins P_3 and P_4 , as seen in the mirror appear to be on the same straight line. If it is so, you have correctly fixed the pins P_3 and P_4 .
6. Remove all the pins and the mirror. Mark the positions of feet of pins P_3 and P_4 . Draw a thin line OQ joining the points that mark the position of feet of pins P_3 and P_4 . Also extend this line till it meets the line SS' . This extended line should meet the surface SS' at the point O . The line OQ shows the path of the reflected ray corresponding to the incident ray along the line PO , at the point of incidence.
7. Measure angles PON ($\angle i$) and NOQ ($\angle r$) and record the values in observation table.
8. Repeat the experiment for two more angles of incidence.

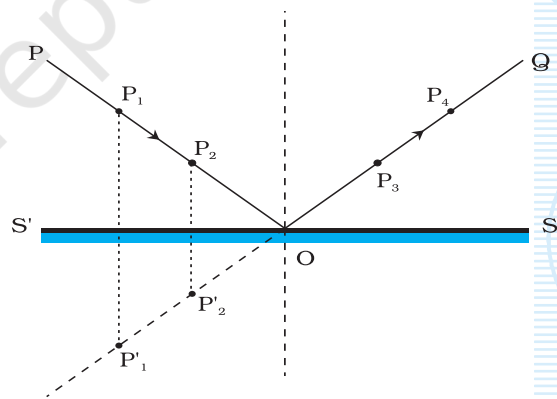

Fig. 34.2 : Verification of laws of reflection

OBSERVATIONS AND CALCULATIONS



Sl.No.	Angle of incidence $\angle i = \angle PON$	Angle of reflection $\angle r = \angle NOQ$	Difference $\angle i \sim \angle r$
1.			
2.			
3.			

RESULTS AND DISCUSSION



1. Does the reflected ray meet the point of incidence for all angles of incidence? Does the reflected ray lie in the plane of incidence? Explain on the basis of your observations.
2. Is the angle of incidence equal to the angle of reflection in each case? If not, is the difference between the two very large?
3. As $\angle i = \angle r$, and the incident ray, normal and the reflected ray lie in the same plane, laws of reflection are verified.

PRECAUTIONS



- Plane mirror must be placed vertically on the plane of paper.
- Mirror should be made of thin glass with a smooth surface (Why? Otherwise many images may be formed due to multiple reflections). It should be of good quality with good reflecting surface.
- The pins P_1 , P_2 , P_3 and P_4 fixed on the paper may not be exactly perpendicular (or vertical) to the plane of paper, Thus, if their feet are collinear, their heads may not appear to be collinear. Therefore while marking the position of the pins on paper, the positions of their feet should be considered for drawing the lines to show the path of incident and the reflected rays. It is done by marking the position of the holes made by the pins.
- While fixing the pins to mark the reflected ray by viewing the images of pins fixed on the path of the incident ray, the eye must be kept at a distance from the pins so that feet of all of them can be simultaneously seen clearly.
- The distance between P_1 and P_2 ; and P_3 and P_4 should not be less than about 5 to 6 cm so that the direction of incident ray and reflected ray can be located with a greater accuracy.

- The eye should be kept at such a position that the distance between the image of the pins and eye is at least 25 cm. Also, while observing the image clearly, one eye should be closed.
- All lines drawn must be thin. A pencil with sharp tip must be used for this purpose.
- The angles should be measured accurately by keeping the eye normally above the marking on the protractor.

NOTE FOR THE TEACHER

- In case if the mirror strip being used in this experiment is thick, one may find that the incident ray and reflected ray do not meet at the same point O on line SS'. This is because of the formation of multiple images due to multiple reflection. It is therefore strongly advised that a thin glass sheet must be used in this experiment. However, it is ideal to use a front-coated mirror.
- The surface irregularities in glass may cause error. For example, the angles of incidence and reflections may not appear to be equal. It is necessary that the mirror strip must be made up of very good quality glass.

QUESTIONS

- Why do we prefer a thin mirror strip to verify the laws of reflection?
- Can you obtain the image of a lighted candle placed in front of a plane mirror on a screen? Justify your answer.
- If the incident ray is perpendicular to the plane mirror, what will be the angle of reflection?
- An incident ray is reflected backwards along the same path, from a plane mirror. What is the angle of incidence?
- A pin is fixed at a distance of 5 cm in front of a plane mirror. Where and at what distance will the image be formed?

Experiment 35

AIM

To draw the images of an object, formed by a concave mirror, when the object is placed at various positions.

THEORY

A concave mirror (a spherical mirror), like a plane mirror obeys the laws of reflection of light. The nature, position and relative size of the

images, formed by a concave mirror, of an object placed at various positions depend on the position of the object with respect to the pole of the concave mirror. The formation of images by a concave mirror can also be studied by drawing ray diagrams, using the new cartesian sign convention (Fig. 35.1).

In this convention, the pole (P) of the mirror MN is taken as the origin and its principal axis as the x-axis (X'X) of the coordinate system. According to this convention: (i) The object is always placed to the left of the mirror. This implies that the light from the object falls on the mirror from the left-hand side; (ii) All distances

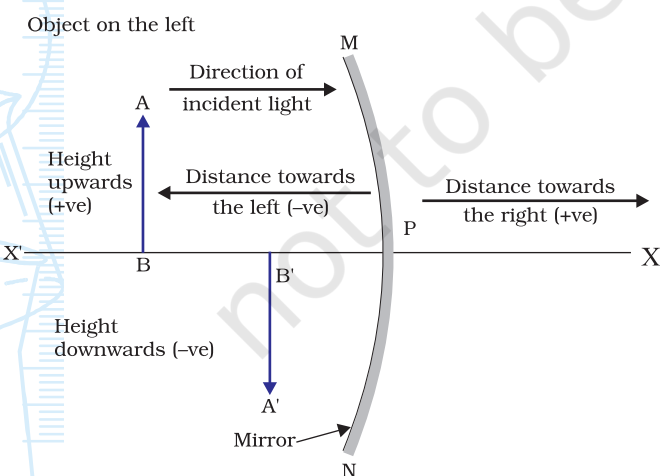

Fig. 35.1 : The New Cartesian Sign Convention for spherical mirrors

parallel to the principal axis are measured from the pole of the mirror; (iii) All distances measured to the right of the origin (that is along the $+x$ -axis) are taken as positive while those measured to the left of the origin (that is along the $-x$ -axis) are taken as negative; (iv) Distances measured perpendicular to and above the principal axis (that is along the $+y$ -axis) are taken as positive; and (v) Distances measured perpendicular to and below the principal axis (that is along the $-y$ -axis) are taken as negative.

For an extended object AB of finite size, placed in front of a concave mirror, its each small portion is assumed to act like a point source. An infinite number of rays of light originate from each of these point sources which could be considered for drawing the ray diagrams in order to locate the image of object AB. For the sake of clarity of the ray diagram, only two rays are considered and so chosen as to know their directions easily after reflection from the concave mirror. Fig. 35.2 illustrates the ray diagrams for the path of incident rays after reflection from the concave mirror. The intersection of at least two reflected rays give the position of image of the point object. Any two of the following rays can be considered for locating the image by a concave mirror:

- (i) A ray parallel to the principal axis, after reflection, will pass through the principal focus F [Fig. 35.2(a)].
- (ii) A ray passing through the principal focus F of a concave mirror, after reflection, will emerge parallel to the principal axis [Fig. 35.2(b)].
- (iii) A ray passing through the centre of curvature C of a concave mirror, after reflection, is reflected back along the same path [Fig. 35.2(c)]. The light rays come back along the same path because the incident rays fall on the mirror along the normal to the reflecting surface.
- (iv) A ray incident obliquely to the principal axis, towards a point P (pole of the mirror), on the concave mirror [Fig. 35.2(d)], is reflected obliquely. The incident and reflected rays follow the laws of reflection at the point of incidence (point P), making equal angles with the principal axis.

Neat ray diagrams can be drawn for various positions of an object in front of a concave mirror, using the new cartesian sign convention (Fig. 35.1) and convenient rays for locating

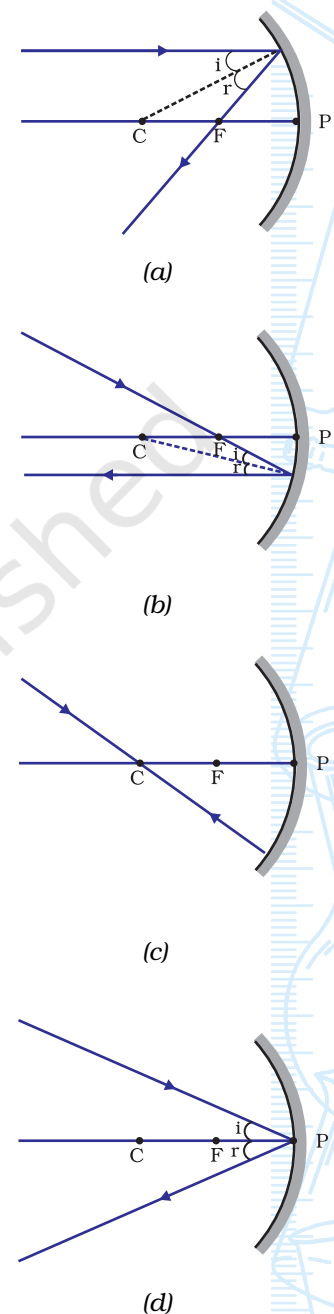

Fig. 35.2 : Any two of the above rays can be considered for locating the image formed by a concave mirror

the image (Fig. 35.2). It may be considered that the concave mirror is thin and that it has a small aperture (Is it necessary?). The nature, position and relative size of the image formed in each case may then be determined.

Normally the spherical mirrors used in school laboratories are polished at the back of a thin transparent glass strip.

MATERIALS REQUIRED



Drawing board, measuring scale, white paper, a pair of compasses, protractor, drawing pins or adhesive tape.

PROCEDURE



1. Fix a white sheet of paper on a drawing board with the help of adhesive tape or drawing pins. At the centre of the white sheet, draw a thin line CP of about 10 - 12 cm length.
2. Place the tip of the compass at point C and draw an arc to represent a concave mirror MM' as shown in Fig. 35.3(a). Here, C represents the centre of curvature, point P the pole, and distance CP the radius of curvature R of the concave mirror.
3. Draw rays from a distant object AB assumed to be placed at infinity in Fig. 35.3(a). Draw two lines, representing incident rays with arrows

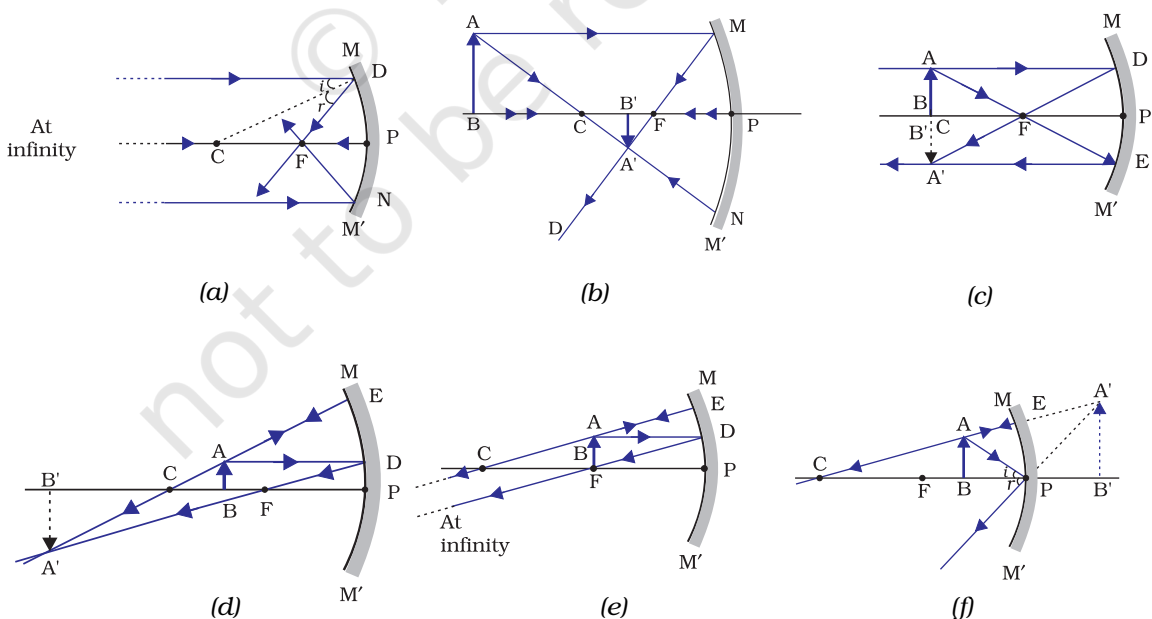
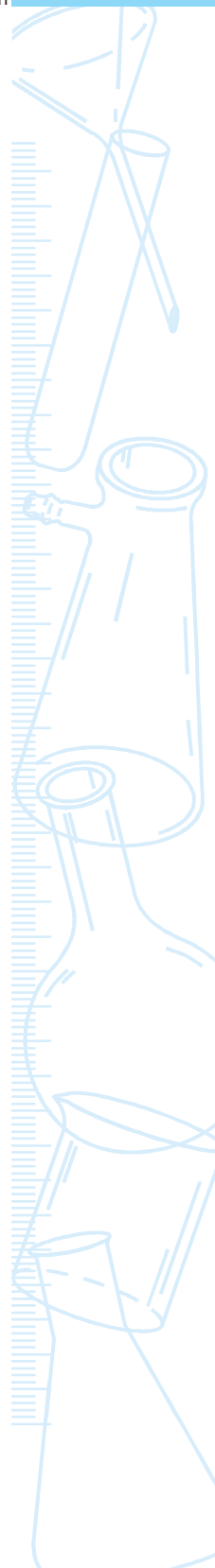

Fig. 35.3 : Ray diagrams for the image formation by a concave mirror

(to show the direction of the ray), on the surface of the concave mirror MM' at points of incidence D and N respectively.

4. Join points D and N to point C by a dotted straight line. Then, lines CD and CN are normal to the curved surface MM' at the points D and N respectively. Here $\angle ADC = \angle BNC = \angle i$, the angle of incidence at points D and N. Measure these angles of incidence in each case.
5. The incident light rays AD and BN will be reflected by the mirror MM' at angles equal to angles of incidence ($= \angle i$) at points D and N. For this, draw a line DF with an arrow, meeting the principal axis at F, such that $\angle CDF$ equals to $\angle ADC$. The $\angle CDF$ is the angle of reflection at the point D (that is, $\angle CDF = \angle r$). Similarly, draw a line from the point N, meeting the principal axis at a point, such that the angle of reflection for the incident ray BN with the normal CN is equal to $\angle BNC (= \angle i)$. Does this reflected ray from point N also meet the principal axis at point F? If so, draw the line NF (as the reflected ray) and mark $\angle CNF = \angle r$, the angle of reflection at the point of incidence N. Then, the point F is the principal focus of the concave mirror.
6. Measure the lengths CF and FP. Is $CF = FP$? (Ideally, the point F must lie mid-way between the points C and P.)
7. Draw a line CP with an arrow to represent the incident ray falling normally on the mirror MM' at the pole of the mirror, P. This ray, after reflection, will pass through the principal focus F. Draw the line PC with an arrow at the point of incidence P. In this situation, the reflected ray PC retraces its path in opposite direction to the incident ray.
8. The reflected rays DF, NF, and PC meet at the principal focus F. Thus the image of the distant object AB (placed at infinity) is formed at the point F, as shown in Fig. 35.3(a).
9. Repeat the above steps, using the New Cartesian Sign Convention (Fig. 35.1) and considering relevant rays for locating the image. Draw neat ray diagrams for each position of the object placed beyond the centre of curvature C [Fig. 35.3(b)]; at the centre of curvature C [Fig. 35.3(c)]; between the centre of curvature C and principal focus F [Fig. 35.3(d)]; at the principal focus F [Fig. 35.3(e)]; and between the pole P and the principal focus F [Fig. 35.3(f)].
10. Measure the height h and h' , using the scale, of the object AB and its image $A'B'$ respectively, formed by the concave mirror MM' in the ray diagram drawn in each case of Figs. 35.3(b) to (f). Record them in the observation table.
11. Describe the nature, position and relative size of the image, formed



by the concave mirror, of the object placed at various positions. Tabulate the results in the observation table.

OBSERVATIONS, RESULTS AND CONCLUSIONS

Formation of image of an object placed at different location/position in front of a concave mirror as illustrated in ray diagrams in Fig. 35.3:i.

Sl. No.	Ray diagram	Position of the object	Position of the image	Nature of the image	Size of the object h (cm)	Size of the image h' (cm)	Magnification (h'/h)
1.	(a)	At infinity	At the focus, F	Real and inverted			
2.	(b)	Beyond C	Between F and C	Real and inverted			
3.	(c)	At C	At C	Real and inverted			
4.	(d)	Between C and F	Beyond C	Real and inverted			
5.	(e)	At F	At infinity	Real and inverted			
6.	(f)	Between P and F	Behind the mirror	Virtual and erect			

PRECAUTIONS

- Use a sharp tip pencil to draw the thin lines to represent incident and reflected rays, and also all other lines.
- Measure the angles of incidence and reflection, using protractor of very good quality with clear markings.
- The tip of a pair of compasses should be sharp for drawing the concave mirror.
- The concave mirror drawn should be thin and of small aperture and sufficiently large radius of curvature for locating a distinct image.

NOTE FOR THE TEACHER

- The position F of a concave mirror should not be marked midway between C and P in a ray diagrams illustrated in Fig. 35.3 (Why?). Its position on the principal axis should be found, using the laws of reflection of light.
- The ray diagrams for the formation of image of an object by a concave mirror can also be drawn on a graph paper. This might facilitate students in making all measurements.

QUESTIONS

- Sometimes the image formed by a concave mirror of an object placed at C is not of the same size and at location C. What could be the possible reason(s) for such a situation?
- In what way will the position and size of the image affected if the pencil used for drawing ray diagrams is not sharp and thin?
- What is the advantage of joining the point C with the point of incidence D, while drawing ray diagrams for the image formation by a concave mirror?

Experiment 36

AIM

To determine the focal length of a concave mirror by obtaining image of a distant object.

THEORY

A concave mirror, like a plane mirror, obeys the laws of reflection of light. The rays of light coming from a distant object such as the sun (or a distant

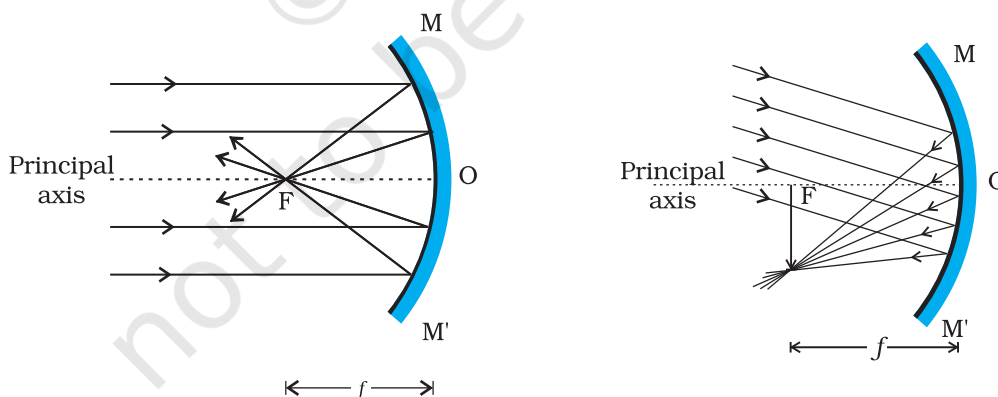

Fig. 36.1 : Image formation of a distant object by a concave mirror

(a) incident parallel rays of light are parallel to the principal axis

(b) incident parallel rays of light are not parallel to the principal axis

tree or a distant building) can be considered to be parallel to each other. When parallel rays of light fall on a concave mirror along its axis, the rays

meet at a point in front of the mirror after reflection from it. This point is the focus of the mirror. For a parallel beam of light coming from a distant object, a real, inverted and very small image size is formed at the focus of the mirror [Fig. 36.1(a)]. Since the image formed by the mirror is real, it can be obtained on a screen. The distance between the pole O of the concave mirror and the focus F is the focal length of the concave mirror. Thus, the focal length of a concave mirror can be estimated by obtaining a real image of a distant object at its focus.

MATERIALS REQUIRED



A concave mirror, a mirror holder, a small screen fixed on a stand, and a measuring scale.

PROCEDURE



1. Fix a concave mirror in the mirror holder and place it on the table near an open window. Turn the face of mirror towards a distant object (a tree or an electricity pole or a distant building).
2. Place the screen fitted to a stand in front of the concave mirror. Move the screen back and forth until a sharp, clear and inverted image of the distant object is formed on it (Fig. 36.2). A clear and bright image could be obtained if the distant object, say a tree or a building, is illuminated with sunlight and the screen is placed in the shade. A bright image of the sun could also be obtained if the sunlight is made to fall directly on the concave mirror.
3. Mark the position of the centre of the stand holding the mirror and the screen when a sharp image of the distant object has been obtained on the screen. Measure the horizontal distance between the centre of the concave mirror and the screen with the help of a measuring scale. Record your observations in the observation table.

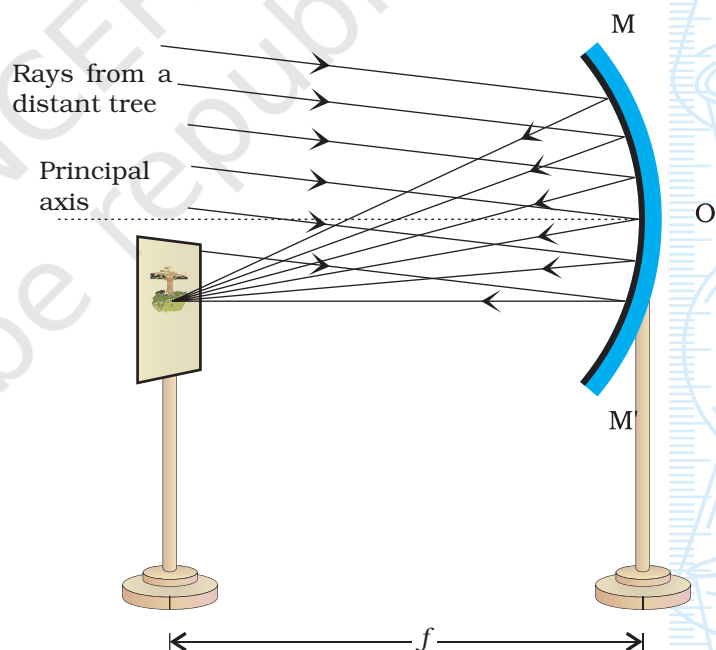

Fig. 36.2 : Determination of focal length of a concave mirror

- Repeat the experiment two more times by obtaining the images of two different distant objects. Measure the distances between the concave mirror and the screen in each case. Record them in the observation table.
- Find the mean value of the focal length.

OBSERVATIONS AND CALCULATIONS



Sl. No.	Name of the distant object	Distance between the concave mirror and the screen, f		Mean focal length of the concave mirror, f
		(cm)	(m)	
1.				
2.				
3.				

RESULTS AND DISCUSSION



The approximate value of focal length of the given concave mirror is ___ m.

PRECAUTIONS



- Concave mirror should be placed near an open window through which sufficient sunlight enters, with its polished surface facing the distant object.
- There should be no obstacle in the path of rays of light from the distant object, incident on the concave mirror.
- The image of the sun should be focussed only on the screen. The image of sun should never be seen directly with the naked eye. Sunlight should never be focussed with a concave mirror on any part of the body, paper or any inflammable materials, as it could be dangerous to do so.
- In order to obtain a sharp and clear image of the distant object on the wall/ground, it must be ensured that the object is well illuminated so that amount of light incident on the concave mirror is sufficient to produce a well illuminated and distinct image.
- The base of the stands of the concave mirror and screen should be parallel to the measuring scale.
- The mirror holder along with the mirror should be kept perpendicular to the measuring scale for precise measurements.

NOTE FOR THE TEACHER

- Use the concave mirror with focal length preferably between 15 cm to 20 cm.
- A distant object does not necessarily mean a very far off object, like a building or a tree or an electricity pole. A well illuminated window or a glowing bulb at a distance of about 10 to 15 m away, even within the science laboratory, may also be taken as a distant object. Why?

QUESTIONS

- How will you distinguish between a concave and a convex mirror?
- To determine the focal length of a concave mirror, a student focuses a classroom window, a distant tree and the sun on the screen with the help of a concave mirror. In which case will the student get more accurate value of focal length?
- What will be the nature of image formed by a concave mirror for a distant object?
- In reflector type solar cookers, special concave (parabolic) mirrors are used. In such cookers, what should be the preferable position of food vessel for cooking?
- What type of mirror is used in a torch? Give reasons.
- What type of mirror is used as shaving mirror or in vanity boxes?

Experiment 37

AIM

To study the formation of an image of a lighted candle by a concave mirror, when placed slightly beyond the centre of curvature.

THEORY

The position, nature and size of the image of an object formed by a concave mirror can be studied, using new cartesian sign conventions and drawing ray diagrams. The ray diagrams for obtaining image formed by a concave mirror of an object when placed at various positions are given in Experiment 35. The position, nature, and size of the image formed depend on the position of the object with respect to the pole P of the concave mirror MM'.

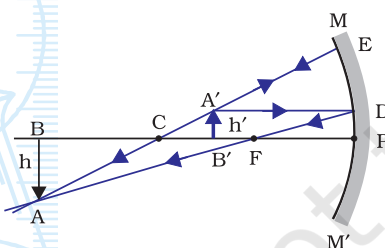

Fig. 37.1 : Formation of an image $A'B'$ formed by a concave mirror MM' (having focal length f and radius of curvature R), when the object AB is placed at slightly beyond the centre of curvature C : A real, inverted and diminished image $A'B'$ lies between the centre of curvature C and principal focus F

Fig. 37.1 summarises the formation of image of an object AB formed by a concave mirror when the object is placed slightly beyond the centre of curvature C .

A real, inverted image can be obtained on a screen. The image of the flame of a lighted candle placed beyond the centre of curvature of a concave mirror can also be focused and obtained on the screen. The nature, position, and size of the image and the flame (object) can be noted and measured from pole P of the concave mirror.

MATERIALS REQUIRED



A concave mirror, a mirror holder (or a stand), a small rice paper screen fixed to a stand, a measuring scale, a small candle with stand, and a match box.

PROCEDURE



1. Hold concave mirror in hand and determine the approximate focal length f of the concave mirror by obtaining sharp image of a distant object (such as the sun or a tree or an electricity pole or a building) on a wall or a screen and measuring the distance between the image and the concave mirror. (This method is explained in detail in Experiment 36) Record it in the observation table. The radius of curvature R of the concave mirror may be taken as twice of its focal length f .
2. Fix the concave mirror vertically in the mirror holder (or stand) and place it on one side edge of the table. Note and record the position of the concave mirror in the observation table.
3. Mount a small candle vertically on a stand and light it. Place it in front of the concave mirror on the left hand side (Fig. 37.2). Adjust the height of the centre of the concave mirror nearly equal to the height of the flame of the candle. Here we consider the flame to be the object AB . Measure and record the height h of the candle flame. (It is important that the flame must not flicker. This will ensure the height h of the flame uniform throughout the experiment. Switch off the fans such that wind does not disturb the flame. Perform the experiment at a dark place.)

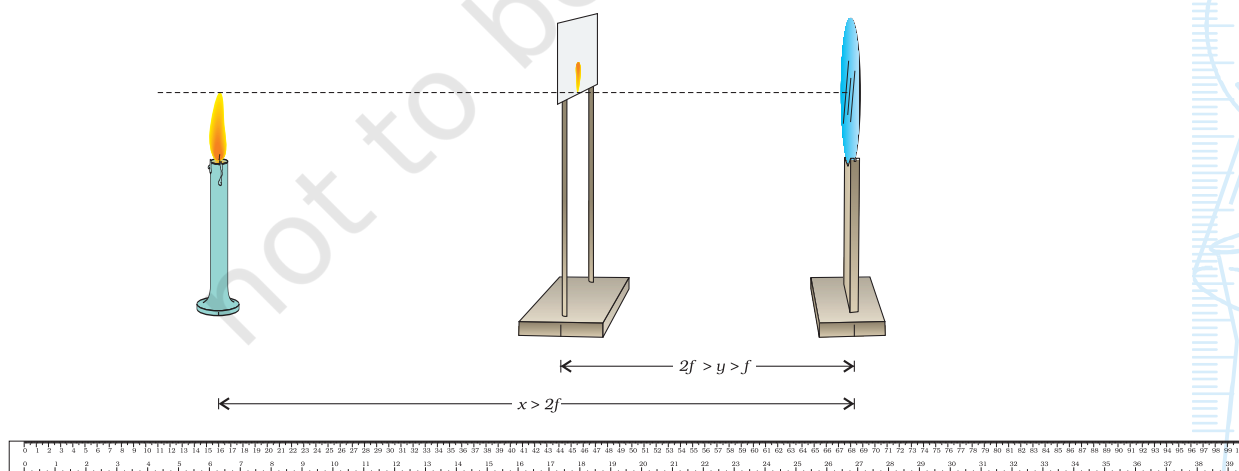

Fig. 37.2 : Locating the image of a lighted candle flame placed beyond the centre of curvature of a concave mirror

4. Place the lighted candle in front of the concave mirror MM' beyond its centre of curvature C (Fig. 37.2). Note and record the position of the candle. Find the distance, x (say) between the pole P of the mirror and candle flame (object). Here $x > 2f$.
5. Place the rice paper (or semi-transparent) screen, fitted to a stand between the centre of curvature C and focus F of the mirror (see Fig. 37.2). The lower level of the screen must be so arranged that it remains just above the principal axis of the mirror. It is suggested to prepare a screen as shown in Fig. 37.2.
6. To locate a sharp image A'B' of candle flame, adjust the position of the screen. Note and record the position of the screen. Find the distance between the pole P of the mirror and the screen, y (say). Here $2f > y > f$. Also measure and record the height h' of the image of the candle flame obtained on the screen.
7. Repeat the experiment two more times by slightly changing x by changing the position of either the concave mirror or the lighted candle. Locate the sharp image of the flame and record the position and height of the image in each case.

OBSERVATIONS AND CALCULATIONS



Approximate focal length of the concave mirror, $f =$ ____ cm.

Height of the candle flame, $h =$ ____ cm.

Nature of the image: _____ .

Sl. No.	Position of the pole P of mirror,	Position of the flame,	Position of the screen,	Distance between pole P and flame,	Distance between pole P and screen,	Size of the image,	Magnification
	c	l	s	$x = l - c$	$y = s - c$	h'	(h' / h)
	(cm)	(cm)	(cm)	(cm)	(cm)	(cm)	
1.							
2.							
3.							

RESULTS AND DISCUSSION



On the basis of your observations, answer the following:

- What is the position of image (screen) with respect to the concave mirror when the object (the flame of the lighted candle) is placed beyond the centre of curvature? Is the distance of the screen from the concave mirror is less than, more than, or equal to the radius of curvature $R (=2f)$?

- Is the size of the image of the candle flame less than, more than, or equal to the size of the candle flame (object)? Interpret the result in terms of the magnification produced by the concave mirror.
- What is the nature of the image obtained on the screen? Is it real or virtual? Is it inverted or erect? Is it magnified (enlarged) or diminished?

PRECAUTIONS AND SOURCES OF ERROR



- For obtaining distinct and sharp images of the candle flame, it is preferable to perform this experiment in a dark room or at least in shade where no direct light reaches the working table.
- To avoid the flickering of the candle flame, perform this experiment in a room with calm air. Switch off the fan while performing this experiment.
- While finding out the approximate value of the focal length f of the concave mirror by using sunlight, do not look at the image directly with the naked eye, otherwise it might damage the eyes.
- The concave mirror should be thin and of good quality polished surface.
- The aperture of the concave mirror (diameter of its reflecting surface) should be small for obtaining a distinct image.
- The eye should be placed at a distance of at least 25 cm from the image formed by the concave mirror on the screen.
- The base of the stands of the concave mirror and screen should be parallel to the measuring scale.

NOTE FOR THE TEACHER

- Experiment 35 titled “*To draw the images of an object formed by a concave mirror when placed at various positions*” aims to learn qualitatively about the formation of images of an object and good to do before this experiment to practise. It is therefore advised that students are suggested to this activity first.
- A semi-transparent rice paper screen is good to use in this experiment. A screen may also be prepared by spreading few drops of an edible oil on a paper.
- The focal length of the concave mirror must preferably be between 15 cm and 20 cm.
- This method gives a rough and intuitive description for locating the image formed by the concave mirror.

QUESTIONS

- How will you distinguish between a concave mirror and a convex mirror by holding in hand and looking into them successively?
- In what way will the image of the lighted candle be affected when the experiment is performed in a bright light area and on a windy day?
- A distinct image of the lighted candle has been obtained on screen with fixed position using a concave mirror. Why does the image of the candle becomes blurred if the position of any one of them is slightly disturbed?
- What effect do you expect if the mirror is thick?
- Normally the mirrors used in school laboratories are polished back on a thin glass sheet. If the mirror is front polished, what effect do you expect in this experiment?
- Why is it preferred to perform this experiment in dark or in shade?
- Why do we require a calm atmosphere to perform this experiment?

Experiment 38

AIM 

To study the formation of an image of a lighted candle by a concave mirror, when placed between the centre of curvature and the principal focus.

THEORY 

The position, nature and size of the image of an object formed by a concave mirror can be studied, using new cartesian sign conventions and drawing ray diagrams. The ray diagrams for obtaining image formed by a concave mirror of an object when placed at various locations position are given in Experiment 35. The position, nature, and size of the image formed depend on the position of the object with respect to the pole P of the concave mirror MM' .

Fig. 38.1 summarises the formation of image of an object AB formed by a concave mirror when the object is placed between the centre of curvature C and focus point F of the concave mirror.

A real, inverted image can be obtained on a screen. The image of the flame of a lighted candle placed between the centre of curvature and focus of a concave mirror can also be focused and obtained on the screen. The nature, position, and size of the image and the flame (object) can be noted and measured from pole P of the concave mirror.

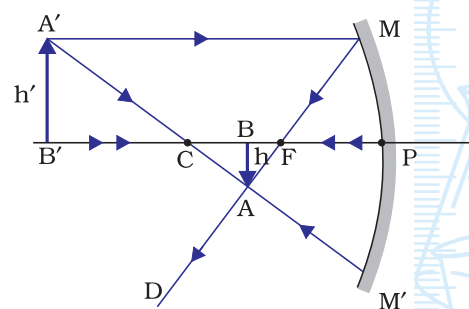

Fig. 38.1 : Formation of an image $A'B'$ formed by a concave mirror MM' (having focal length f and radius of curvature R), when the object AB is placed between the centre of curvature C and focus point F : A real, inverted and larger size image $A'B'$ lies beyond the centre of curvature C

MATERIALS REQUIRED



A concave mirror, a mirror holder (or a stand), a small rice paper screen fixed to a stand, a meter scale, a small candle with stand, and a match box.

PROCEDURE



1. Hold the concave mirror and determine the approximate focal length f of the concave mirror by obtaining sharp image of a distant object (such as the sun or a tree or a building) on a wall or a screen and measuring the distance between the image and the concave mirror. (This method is explained in detail in Experiment 36.) Record it in the observation table. The radius of curvature R of the concave mirror may be taken as twice of its focal length f .
2. Fix the concave mirror vertically in the mirror holder and place it on one side edge of the table. Note and record the position the concave mirror in the observation table.
3. Mount a small candle vertically on a stand and light it. Place it in front of the concave mirror on the left hand side (Fig. 38.2). Adjust the height of the centre of the concave mirror nearly equal to the height of the flame of the candle. Here we consider the flame to be the object AB . Measure and record the height h of the candle flame. (It is important that the flame must not flicker. This will ensure the height h of the flame uniform throughout the experiment. Switch off the fans so that wind does not disturb the flame. Perform the experiment at a dark place.)

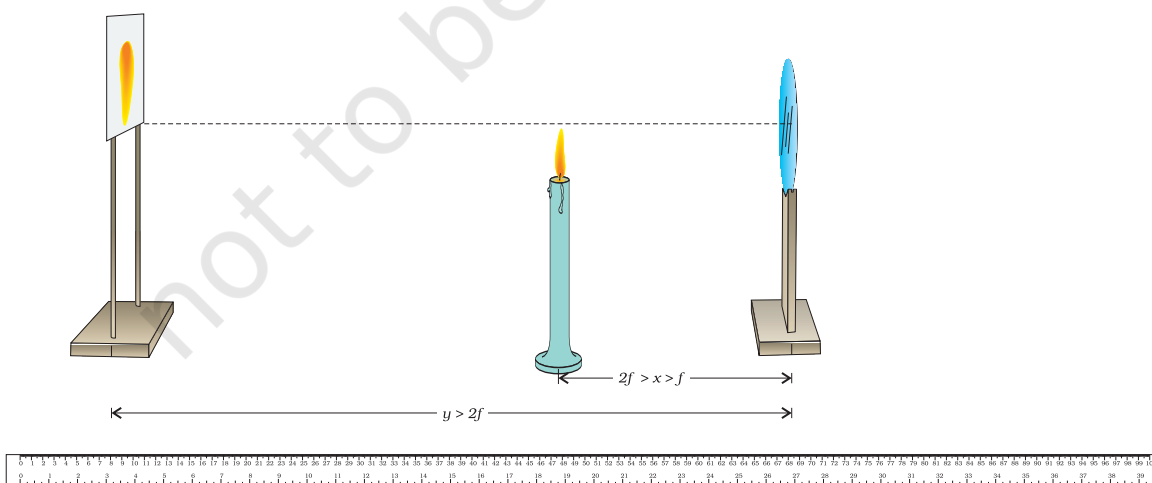

Fig. 38.2 : Locating the image of a lighted candle flame placed in between the centre of curvature and focus of a concave mirror

- Place the lighted candle in front of the concave mirror between the centre of curvature C and focus F of the concave mirror MM' (Fig. 38.2). Note and record the position of the candle. Find the distance, x between the pole P of the mirror and candle flame (object). Here $2f > x > f$.
- Place the semi transparent rice paper screen beyond the centre of curvature C of the mirror (Fig. 38.2). [The lower level of screen must be so arranged that it remains just above the principal axis of the mirror. It is suggested to prepare a screen as shown in Fig. 35.2.] Locate a sharp image $A'B'$ of candle flame by adjusting the position of the screen. Note and record the position of the screen. Find the distance between the pole P of the mirror and the screen, y . Here $y > 2f$. Also measure and record the height h' of the image of the candle flame obtained on the screen.
- Repeat the experiment two more times by slightly changing x , by changing the position of either concave mirror or the lighted candle. Locate the sharp image of the flame and record the position (y) and height h' of the image in each case.

OBSERVATIONS AND CALCULATIONS



Approximate focal length of the concave mirror, $f =$ _____ cm.

Height of the candle flame, $h =$ _____ cm.

Nature of the image: _____ .

Sl. No.	Position of the pole P mirror, c	Position of the flame, l	Position of the screen, s	Distance between pole P and flame	Distance between pole P and screen	Size of the image, (h' / h)	Magnification
	(cm)	(cm)	(cm)	$x = l - c$ (cm)	$y = s - c$ (cm)	h' (cm)	
1.							
2.							
3.							

RESULTS AND DISCUSSION



On the basis of your observations, answer the following:

- What is the position of the screen with respect to the concave mirror when the object (the flame of the lighted candle) is placed in between of the centre of curvature and focus of the concave mirror? Is the position of the screen less than, more than, or equal to the radius of curvature $R (=2f)$? Explain on the basis of your observations.

- Is the size of the image of the candle flame less than, more than, or equal to the size of the object candle flame? Interpret the result in terms of magnification produced by the concave mirror.
- What is the nature of the image obtained on the screen? Is it real or virtual? Is it inverted or erect? Is it magnified (enlarged) or diminished?

PRECAUTIONS AND SOURCES OF ERROR



- For obtaining distinct and sharp images of the candle flame, it is advantageous to perform this experiment in a dark room (or at least in shade where no direct light reaches to the working table).
- To avoid the flickering of the candle flame, perform this experiment in calm air. Switch off the fan while performing this experiment.
- While finding out the approximate value of the focal length f of the concave mirror by using sunlight, do not look at the image directly with the naked eye, otherwise it might damage the eyes.
- The concave mirror should be thin and of good quality polished surface.
- The aperture of the concave mirror should be small for obtaining the distinct image.
- The eye should be placed at a distance of at least 25 cm from the image by the concave mirror on the screen.
- The base of the stands of the concave mirror and screen should be parallel to the measuring scale.

NOTE FOR THE TEACHER

- Experiment 35 titled “*To draw the images of an object formed by a concave mirror when placed at various positions*” aims to learn qualitatively about the formation of images of an object and good to do before this experiment to practise. It is therefore advised that students are suggested to this activity first.
- A semi transparent rice paper screen is good to use in this experiment. A screen may also be prepared by spreading few drops of an edible oil on a paper.
- The focal length of the concave mirror must preferably be between 15 cm and 20 cm.
- This method gives rough and intuitive description for locating the image formed by the concave mirror.

QUESTIONS

- How will you distinguish between a concave mirror and a convex mirror by holding in hand and looking into them?
- In what way would the image of the lighted candle be affected when the experiment is performed in a bright light and on a windy day.
- A distinct image of the lighted candle has been obtained on screen with fixed position using a concave mirror. Why does the image of the candle get blurred if the position of any one of them slightly is disturbed?
- What kind effect do you expect if the mirror is thick?
- Normally the mirrors used in school laboratories are polished (or coated) on back on a thin glass. If the mirror is front polished, what effect do you expect in this experiment?
- Why is it preferred to perform this experiment in dark or in shade?
- Why do we require a calm atmosphere to perform this experiment?

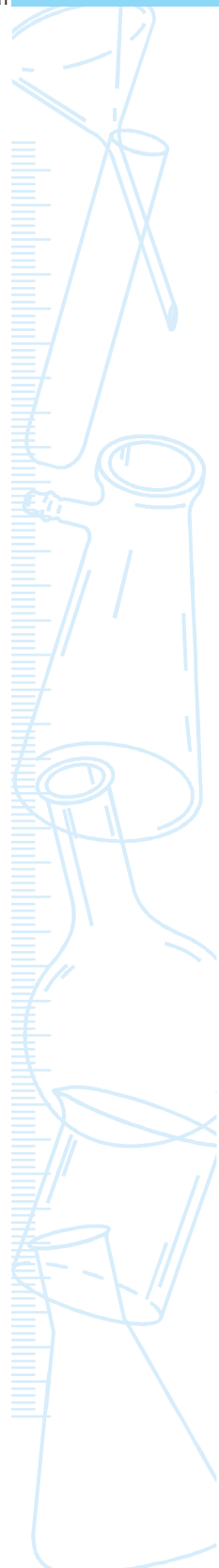

Experiment 39

AIM



To study the formation of an image of a lighted candle by a concave mirror, when placed at the centre of curvature.

THEORY



The position, nature and size of the image of an object formed by a concave mirror can be studied, using new cartesian sign conventions and drawing ray diagrams.

The ray diagrams for obtaining image formed by a concave mirror of an object when placed at various locations position are given in Experiment 35. The position, nature and size of the image formed depend on the position of the object with respect to the pole P of the concave mirror MM' .

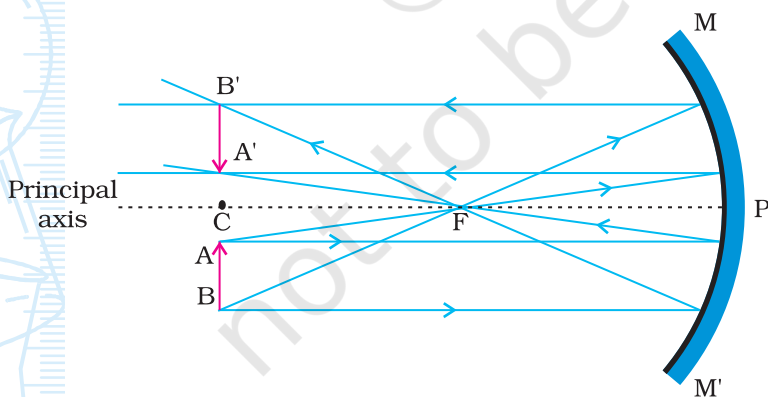

Fig. 39.1 : Formation of an image $A'B'$ formed by a concave mirror MM' (having focal length f and radius of curvature R) when the object AB is placed at the centre of curvature C : A real, inverted and equal size image $A'B'$ lies at the centre of curvature C itself

Fig. 39.1 summarises the formation of image of an object AB formed by a concave mirror when the object AB is placed at the centre of curvature C of the concave mirror.

A real, inverted image can be obtained on a screen. The image

of the flame of a lighted candle placed at the centre of curvature of a concave mirror can also be focused and obtained on the screen. The nature, position, and size of the image and the flame (object) can be noted and measured from pole P of the concave mirror.

MATERIALS REQUIRED



A concave mirror, a mirror holder, a semi-transparent small rice paper screen fixed to a stand, a meter scale, and a small candle with stand, and a match box.

PROCEDURE



1. Hold concave mirror in hand and determine the approximate focal length f_a of the concave mirror by obtaining sharp image of a distant object (such as the sun or a tree or an electricity pole or a building) on a wall or a screen and measuring the distance between the image and the concave mirror. (This method is explained in detail in Experiment 36.) Record it in the observation table. The radius of curvature R of the concave mirror may be taken as twice of its focal length f .
2. Fix the concave mirror vertically in the mirror holder (or stand) and place it on one side edge of the table. Note and record the position the concave mirror (c) in the observation table.
3. Mount a small candle vertically on a stand and light it. Place it in front of the concave mirror on the left hand side (Fig. 39.2). Adjust the centre of the concave mirror at a height which is slightly more than the height of the flame of the candle. Here we consider the flame as object AB. Measure and record the height h of the candle flame. (It is important that the flame must not flicker. Switch off the fans so that wind does not disturb the flame. Perform the experiment at a dark place.)

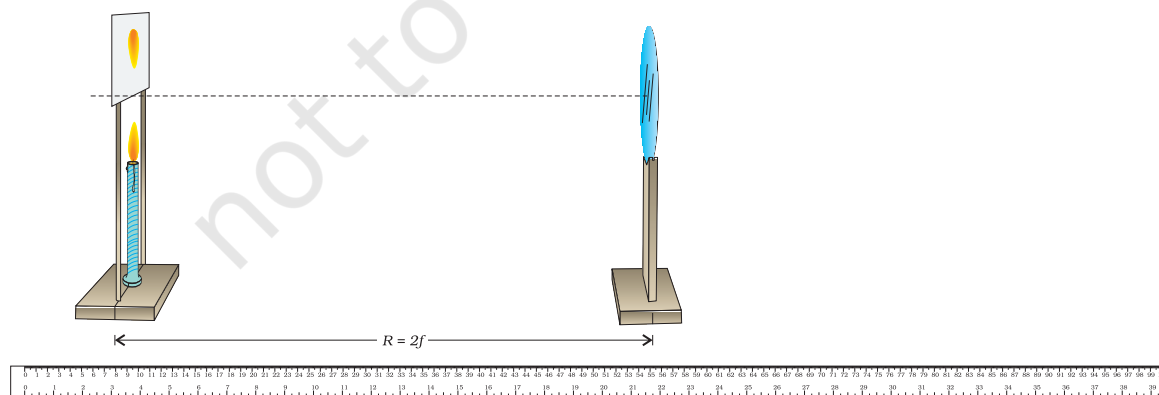

Fig. 39.2 : Image of a lighted candle flame placed at the centre of curvature of a concave mirror is formed at the centre of curvature itself

4. Place the lighted candle in front of the concave mirror MM' at a distance nearly equal to $2f$ or R from the pole P of the mirror (Fig. 39.2). From Experiment 35, we know that the image of an object placed at the centre of curvature of a concave mirror is also formed at the centre of curvature.
5. Place the semi-transparent rice paper screen stand just above the candle flame (Fig. 39.2). The level of screen must be slightly higher than the flame (otherwise the screen may burn). Recall that in this experiment it is suggested to keep the object flame AB below the principal axis of the concave mirror MM' . In this situation, the image of the flame will be formed just above the principal axis of the mirror (Fig. 39.1). Thus you can safely place the candle and screen in the same vertical plane.
6. Adjust the position of the candle flame and screen (together) to get a sharp image $A'B'$ of candle flame on the screen. (Keep the screen and flame in the same vertical plane.) Note and record the position (s) of the candle/screen. This is the position of the centre of curvature of the given concave mirror. Find the radius of curvature R as the distance between the pole P of the mirror and screen/candle flame.
7. Measure the height h' of the image of the flame formed on the screen. Is it equal to the height of the object flame h ?
8. Repeat the experiment at least two more times by changing the position of concave mirror. Record observations in the observation table.
9. Determine the mean value of the radius of curvature R of the concave mirror. Also find the focal length of the mirror.

OBSERVATIONS AND CALCULATIONS



Approximate focal length of the concave mirror, $f_a =$ ___ cm.

Mean value of the radius of curvature R of the given concave mirror = ___ cm.

Focal length of the given concave mirror $f_o = R/2 =$ ___ cm.

Sl. No.	Position of the pole P of the mirror, c	Height of the candle flame, h	Position of the flame/ screen, s	Distance between pole P and flame/ screen	Nature of the image	Height of the image, h'	Magnification (h'/h)
	(cm)	(cm)	(cm)	$R = s - c$ (cm)		(cm)	
1.							
2.							
3.							

RESULTS AND DISCUSSION



The approximate focal length, determined using a rough method, of the given concave mirror is ___ cm. The observed focal length of the mirror is ___ cm. The difference between the two is ___ cm, which is negligibly small (If not, then discuss about the reasons.)

Is the image of flame formed by the concave mirror in the present situation real or virtual? Is it magnified or diminished or of same size? Is it inverted or erect?

PRECAUTIONS AND SOURCES OF ERROR



- For obtaining distinct and sharp images of the candle flame, it is preferable to perform this experiment in a dark room (or at least in shade where no direct light reaches to the working table).
- To avoid the flickering of the candle flame, perform this experiment in calm air. Switch off the fan while performing this experiment.
- While finding out the approximate value of the focal length f of the concave mirror by using sunlight, do not look at the image directly with the naked eye, otherwise it might damage the eyes.
- The concave mirror should be thin and of good quality polished surface.
- The aperture of the concave mirror should be small for obtaining the distinct image.
- The eye should be placed at a distance of at least 25 cm from the image by the concave mirror on the screen.
- The base of the stands of the concave mirror and screen should be parallel to the measuring scale.

NOTE FOR THE TEACHER

- Experiment 35 titled “*To draw the images of an object formed by a concave mirror when placed at various positions*” aims to learn qualitatively about the formation of images of an object and good to do before this experiment to practise. It is therefore advised that students may be suggested to this activity first.
- A rice paper screen is good to use in this experiment. However a semi-transparent sheet may also be used. A screen may be prepared by spreading few drops of an edible oil on a paper.
- The focal length of the concave mirror must preferably be between 15 cm and 20 cm.
- Students may find this experiment difficult to perform, as it is quite difficult and cumbersome to mount both the screen and

the lighted candle at the same position on the table. It is advised that the stand of the screen must be so chosen that the lighted candle may be placed in the centre of it (see Fig. 39.2). The candle to be used must also be very small (small candles used for decorating celebration cakes may be used).

QUESTIONS

- In what way will the image of the lighted candle be affected when the experiment is performed in a bright light and on a windy day.
- A distinct image of the lighted candle has been obtained on screen with fixed position using a concave mirror. Why does the image of the candle becomes blurred if the position of any one of them slightly is disturbed?
- What kind of effect do you expect if the mirror is thick?
- Normally the mirrors used in school laboratories are polished on the back on a thin glass. If the mirror is front polished, what effect do you expect in this experiment?
- Why is it preferred to perform this experiment in dark or in shade?
- Why do we require a calm atmosphere to perform this experiment?

Experiment 40

AIM

To trace the path of a ray of light passing obliquely through a rectangular glass slab for different angles of incidence and to measure the angle of incidence, angle of refraction, the angle of emergence and interpret the results.

THEORY

When a ray of light passes from air to glass through a rectangular glass slab, it bends towards the normal at the surface of the air-glass boundary (AD), as shown in Fig. 40.1. The phenomenon of change in the direction of a ray of light when it enters from one medium to the other is known as refraction. In Fig. 40.1, the angle XON between the incident ray XO and normal NOM at the point of incidence O is the angle of incidence ($\angle i$). The angle MOO' between the refracted ray OO' and the normal NOM is the angle of refraction ($\angle r$). Then, the refracted ray OO' strikes the face BC of the glass slab that forms the glass-air boundary at the opposite face of the glass slab $ABCD$. It undergoes refraction again. The deviation of the ray of light this time is away from the normal $M'O'N'$ at the point of incidence O' . The refracted ray $O'Y$ is known as the emergent ray with respect to the incident ray XO incident at the face

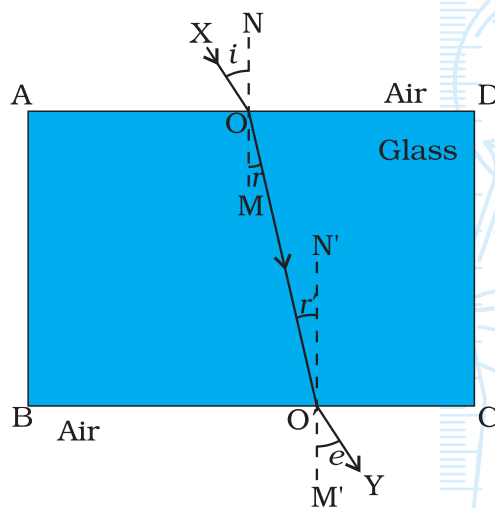

Fig. 40.1 : Incident and emergent rays in the case of refraction through a glass slab

AD. The angle between the emergent ray $O'Y$ and the normal $M'O'N'$ to the face BC (that is angle $M'O'Y$) is known as angle of emergence ($\angle e$).

MATERIALS REQUIRED



A rectangular glass slab, drawing board, white sheet of paper, protractor, a measuring scale, pins, and drawing pins or adhesive tape.

PROCEDURE



1. Fix a white sheet of paper on a drawing board. Place the rectangular glass slab in the middle of the paper and mark its boundary ABCD with a pencil (Fig. 40.2).
2. Remove the rectangular glass slab. Draw a thin line XO (with an arrow) inclined to the face AD of the glass slab at any angle preferably between 30° and 60° . It is advisable to take point O in the middle of the line AD. Replace the glass slab exactly over the boundary mark on the paper.
3. Fix two pins P_1 and P_2 vertically about 5 cm apart, by gently pressing their heads with thumb on the line XO. Observe the images of pins P_1 and P_2 through the face BC of the rectangular glass slab. While observing the images of the pins P_1 and P_2 through the face BC of the glass slab, fix two more pins at points P_3 and P_4 such that feet of all the pins appear to be in a straight line. In other words, the pins P_3 and P_4 are collinear with the images of pins P_1 and P_2 .

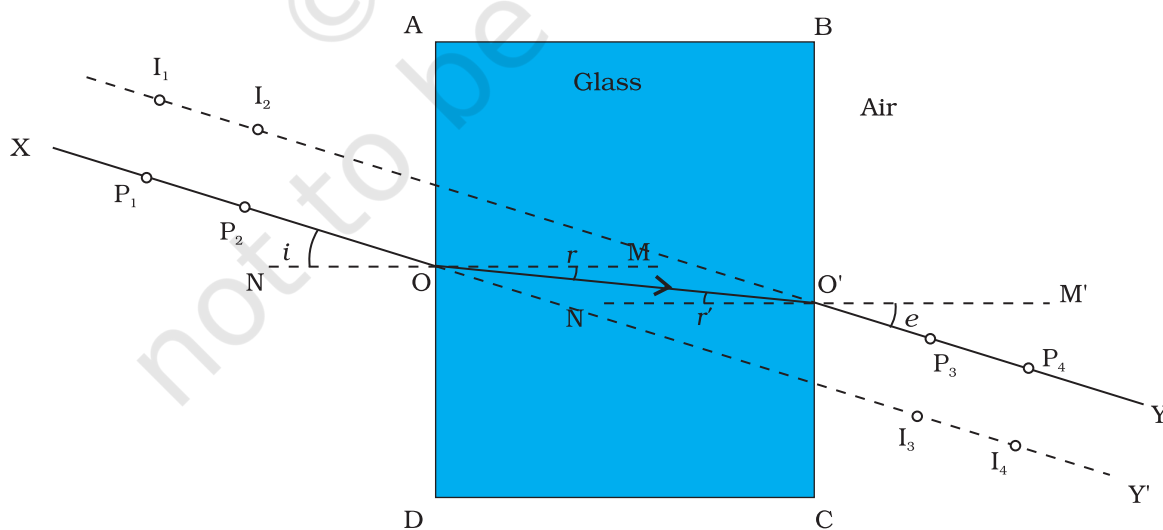

Fig. 40.2 : The images of pins P_1 and P_2 appear to be at I_1 and I_2 when viewed through the face BC while I_3 and I_4 , show the position of the images of pins P_3 and P_4 when viewed through the face AD

- You can also verify the collinearity of pins P_3 and P_4 with the images of pins P_1 and P_2 by looking all four pins through the face AD.
- Remove the pins and the glass slab and mark the positions of the feet of all the four pins. Join points that mark the positions of the pins P_3 and P_4 and extend the line up to point O' where it meets the face BC. Also join the points O and O' as shown in Fig. 40.2, where $XOO'Y$ shows the path of a ray of light passing through the glass slab. The line XP_1P_2O represents the incident ray. Line OO' shows the path of refracted ray in glass slab while line $O'P_3P_4Y$ shows the emergent ray.
- Draw the normal NOM to the face AD at the point of incidence O and similarly the normal $M'O'N'$, to the face BC at point O' . Measure the angle of incidence $\angle XON$ ($\angle i$), angle of refraction $\angle MOO'$ ($\angle r$), and angle of emergence $\angle M'O'Y$ ($\angle e$). Record the values of angles $\angle i$, $\angle r$, and $\angle e$ in the observation table.
- Repeat the experiment for two more angles of incidence in the range 30° to 60° and record the values of angles $\angle i$, $\angle r$, and $\angle e$ in each case.

OBSERVATIONS



Sl. No.	Angle of incidence	Angle of refraction	Angle of emergence	Deviation
	$\angle i = (\angle XON)$	$\angle r = (\angle MOO')$	$\angle e = (\angle M'O'Y)$	$\angle i \sim \angle e$
1.				
2.				
3.				

RESULTS AND DISCUSSION



- The paths of different rays of light through a glass slab are shown in Fig. 40.2 (attach all sheets).
- Report on the relation between the angle of incidence, angle of refraction and the angle of emergence based on different sets of observations taken.
- As $\angle r < \angle i$ in each case, the ray entering from air to glass (denser medium) bends towards normal.
- As $\angle i = \angle e$, the emergent ray emerging out of the rectangular glass slab, is parallel to, but laterally displaced with respect to the incident ray.
- Angle of refraction $\angle r$ increases with increase in angle of incidence $\angle i$.

PRECAUTIONS AND SOURCES OF ERROR



- The glass slab should be perfectly rectangular with all its faces smooth.
- The tips of pins P_1 , P_2 , P_3 , and P_4 should be sharp. These pins fixed on the sheet of paper may not be exactly perpendicular (or vertical) to the plane of paper. Thus, if their heads appear to be collinear, their feet may not be so. It must, therefore, be important to look at the feet of pins and their images while ascertaining collinearity between them. The mark of the pointed end or the foot of a pin on the paper must be considered while marking its position.
- While viewing the collinearity of pins and images, the eye should be kept at some distance from the pins so that the feet of all of them can be seen simultaneously in the same straight line.
- While fixing the pins P_1 and P_2 or the pins P_3 and P_4 , care should be taken to maintain a distance of about 5 cm between the two pins. This would help in tracing the direction of incident ray and that of emergent ray with greater accuracy.
- The angle of incidence should preferably be between 30° and 60° .
- Thin lines should be drawn, using a sharp pencil.
- The angles should be measured accurately, using a good quality protractor having clear markings, by keeping the eye above the marking.

QUESTIONS

- Why are the incident and emergent rays parallel to each other in case of a rectangular glass slab?
- Why does a ray of light bend towards the normal when it enters from air in a glass slab and bends away from the normal when it emerges out into air?
- Draw the path of a ray of light when it enters perpendicular to the surface of a glass slab.
- While tracing the path of ray of light through a glass slab, the angle of incidence is generally taken between 30° and 60° . Explain the reason on the basis of your performing this experiment for different angles of incidence.
- How does the lateral displacement of emergent ray depend on the width of the glass slab and angle of incidence?

Experiment 41

AIM

To trace the path of a ray of light passing obliquely through a rectangular glass slab and to determine the refractive index of the glass.

THEORY

When a ray of light passes from air to glass through a rectangular glass slab, it bends towards the normal to the surface of the air-glass boundary (AD), as shown in Fig. 41.1. The phenomenon of change in the direction of a ray of light when it enters from one medium to the other is known as refraction. In Fig. 41.1, the angle $\angle XON$ between the incident ray XO and normal NOM at the point of incidence O is the angle of incidence ($\angle i$). The angle $\angle MOO'$ between the refracted ray OO' and the normal NOM is the angle of refraction ($\angle r$). Then, the refracted ray OO' strikes the face BC of the glass slab that forms the glass-air boundary at the opposite face of the glass slab $ABCD$. It undergoes refraction again. The deviation of the ray of light this time is away from the normal $M'O'N'$ at the point of incidence O' . The refracted ray $O'Y$ is known as the emergent ray with respect to the incident ray XO incident at the face AD . The angle between the emergent ray $O'Y$ and the normal $M'O'N'$ to the face BC (that is angle

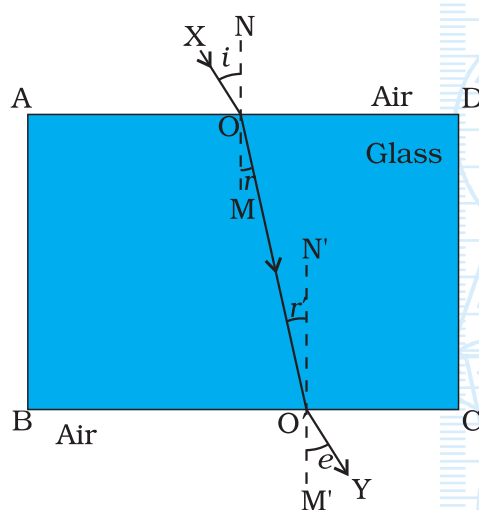

Fig. 41.1 : Incident and emergent rays in case of refraction through a glass slab

M'O'Y) is known as angle of emergence ($\angle e$). Line OO' represent the path of refracted ray in rectangular glass slab.

The refractive index n of glass with respect to air is defined as

$$n = \frac{\text{Speed of light in vacuum or air } (c)}{\text{Speed of light in glass } (v)} \quad (1)$$

Using Snell's law of refraction of light, and from Fig. 41.1, the refractive index (n) of glass can also be expressed as:

$$n = \frac{\sin i}{\sin r}$$

The refractive index of the material of a glass slab is constant for a given colour (or wavelength) and for the given media. The speed of light is greater in a rarer medium (air) than a denser medium (glass). Then, a ray of light, travelling from a rarer medium (air) to a denser medium (glass), slows down and bends towards the normal at the air-glass boundary (Fig. 41.1). When it travels from a denser (glass) to rarer medium (air), it speeds up and bends away from the normal at the glass-air boundary. For air-glass boundary AD, the angle of incidence is angle XON (or $\angle i$), and the angle of refraction is angle MOO' (or $\angle r$). At the glass-air boundary BC, the angle of incidence is the angle OO'N' (or $\angle r'$) and angle of refraction (or the angle of emergence, $\angle e$) is angle M'O'Y.

The refractive index of glass can either be calculated at the air-glass boundary AD or at the glass-air boundary BC (Fig. 41.2).

$$\text{At air-glass boundary AD, } n = \frac{\sin \angle XON}{\sin \angle MOO'} = \frac{\sin \angle i}{\sin \angle r} \quad (2)$$

$$\text{and at glass-air boundary BC, } \frac{1}{n} = \frac{\sin \angle M'O'Y}{\sin \angle OO'N'}$$

$$\text{Thus, } n = \frac{\sin \angle OO'N'}{\sin \angle M'O'Y} = \frac{\sin \angle e}{\sin \angle r} \quad (3)$$

MATERIALS REQUIRED



A rectangular glass slab, drawing board, white sheet of paper, protractor, drawing pins (or adhesive tape), pins, a measuring scale (or a ruler), and Tables of Natural Sines.

PROCEDURE



1. Fix a white sheet of paper on a drawing board. Place the rectangular glass slab in the middle of the paper and mark its boundary ABCD with a pencil (Fig. 41.2).
2. Remove the rectangular glass slab. Draw a thin line XO (with an arrow) inclined to the face AD of the glass slab at any angle preferably between 30° to 60° . It is advisable to take point O in the middle of the line AD. Replace the glass slab exactly over the boundary mark on the paper.

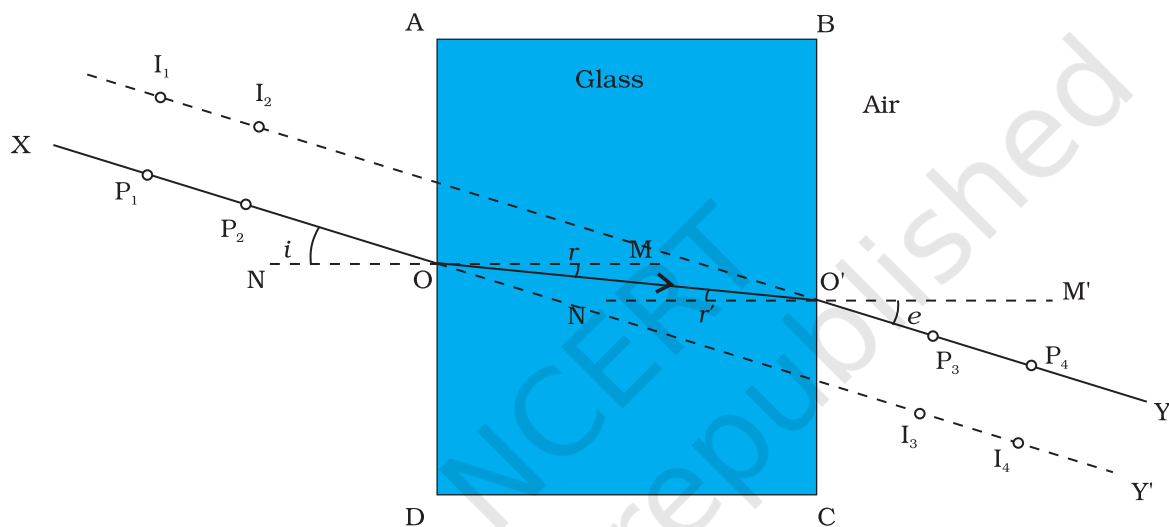

Fig. 41.2 : The images of pins P_1 and P_2 appear to be at I_1 and I_2 when viewed through the face BC while I_3 and I_4 show the position of the images of pins P_3 and P_4 when viewed through the face AD. And measurement of angles at air-glass boundary AD and at glass-air boundary BC

3. Fix two pins P_1 and P_2 vertically, by gently pressing their heads with thumb on the line XO. Observe the images of pins P_1 and P_2 through the face BC of the rectangular glass slab. While observing the images of the pins P_1 and P_2 through the face BC of the glass slab, fix two more pins at points P_3 and P_4 such that feet of all the pins appear to be in a straight line. In other words, the pins P_3 and P_4 are collinear with the images of pins P_1 and P_2 .
4. You can also verify the collinearity of pins P_3 and P_4 with the images of pins P_1 and P_2 by looking all four pins through the face AD.
5. Remove the pins and the glass slab and mark the positions of the feet of all the four pins. Join points that mark the positions of the pins P_3 and P_4 and extend the line up to point O' where it meets the face BC.

Also join the points O and O' as shown in Fig. PX8.2, where XOO'Y shows the path of a ray of light passing through the glass slab. The line XP₁P₂O represents the incident ray. Line OO' shows the path of refracted ray in glass slab while line O'P₃P₄Y shows the emergent ray.

- Draw the normal NOM to the face AD at the point of incidence O and similarly the normal M'O'N', to the face BC at point O'. Measure and record values of the angles $\angle XON$, $\angle MOO'$, $\angle OO'N'$, and $\angle M'O'Y$.
- Find the values of sine of angles $\angle XON$ ($= \angle i$), $\angle MOO'$ ($= \angle r$), $\angle OO'N'$ ($= \angle r'$), and $\angle M'O'Y$ ($= \angle e$), using the Tables of natural sines. Using Eqs. (1) and (2), calculate the refractive index of the glass at air-glass boundary AD and at glass-air boundary BC.
- Repeat the experiment for two more angles of incidence in the range 30° to 60°.
- Find the average (or mean) value of the refractive index of the glass material of rectangular slab.

OBSERVATIONS AND CALCULATIONS



Sl. No.	Face AD		Face BC		n at air-glass boundary AD	n at glass-air boundary BC
	$\angle XON$ ($= \angle i$)	$\angle MOO'$ ($= \angle r$)	$\angle M'O'Y$ ($= \angle r'$)	$\angle M'O'Y$ ($= \angle e$)	[Eq. (2)]	[Eq. (3)]
1.						
2.						
3.						

RESULTS AND DISCUSSION



- The path of different rays of light through a rectangular glass slab is as shown in Fig. 41.2 (attach all sheets).
- Are the values of refractive index of glass with respect to air at air-glass boundary AD and glass-air boundary BC same? The mean value of refractive index n is _____.

PRECAUTIONS AND SOURCES OF ERROR



- The glass slab should be rectangular with all its faces smooth.
- The tips of pins P₁, P₂, P₃, and P₄ should be sharp. These pins fixed on the sheet of paper may not be exactly perpendicular (or vertical) to the plane of paper. Thus, if their heads appear to be collinear, their feet may not be so. It must therefore be important to look at the feet of pins and their images while ascertaining collinearity between them. The mark

of the pointed end or the foot of an pin on the paper must be considered while marking its position.

- While viewing the collinearity of pins and images, the eye should be kept at some distance from the pins so that the feet of all of them can be seen simultaneously in the same straight line.
- While fixing the pins P_1 and P_2 or the pins P_3 and P_4 , care should be taken to maintain a distance of approximately 6 cm between the two pins. This would help in tracing the direction of incident ray and that of emergent ray with greater accuracy.
- The angle of incidence should preferably be between 30° and 60° .
- Thin lines should be drawn, using a sharp pencil.
- The angles should be measured accurately, using a good quality protractor having clear markings, by keeping the eye above the marking.

QUESTIONS

- Why does a ray of light bend towards the normal when it enters from air in a glass slab and bends away from the normal when it emerges out into air?
- Draw the path of a ray of light when it enters perpendicular to the surface of a glass slab.
- If the incident and emergent rays are not parallel to each other in case of a rectangular glass slab, what could be the reason?
- While tracing the path of ray of light through a glass slab, the angle of incidence is generally taken between 30° and 60° . Explain the reason on the basis of your performing this experiment for different angles of incidence.
- How does the lateral displacement of emergent ray depend on the width of the glass slab and angle of incidence?
- On what factors does the refractive index of a medium depend?
- Is Snell's law obeyed in case of normal incidence of light on a rectangular glass slab?

Experiment 42

AIM

To trace the path of a ray of light through a glass prism and to measure the angle of deviation.

THEORY

When a ray of light (DE) from air strikes on a face AB of a triangular glass prism ABC, it gets refracted and bends towards the normal to the plane of the face AB (Fig. 42.1). The refracted ray EF travels inside the prism until

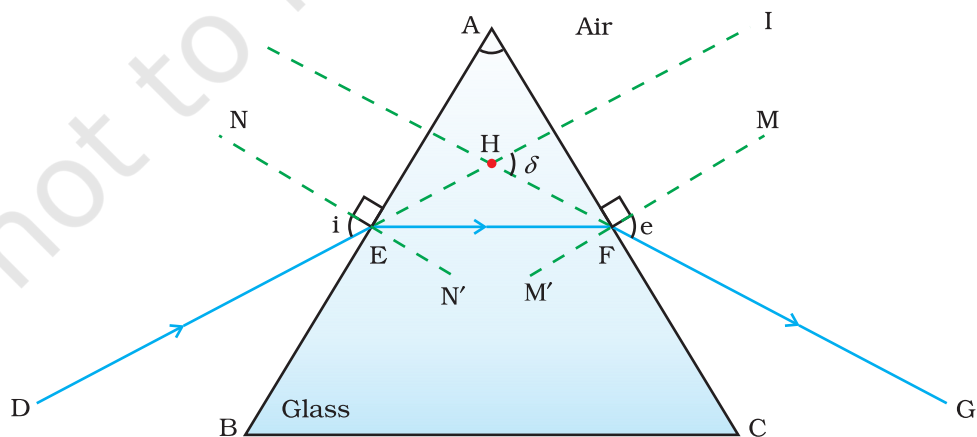

Fig. 42.1 : Refraction of light through a prism

it strikes its other face AC. Here again, the ray from glass gets refracted into air but bends away from the normal towards the face BC. The ray FG is the ray that emerges out of the glass prism at the glass-air boundary face AC. The ray FG that emerges out of the glass prism at the face AC after successive refractions is the emergent ray (Fig. 42.1). Usually the emergent ray is bent towards the base (BC) of the prism as shown. The angle $\angle IHG$ between the incident ray DE (when extended) and the emergent ray FG, when produced backwards to meet at a point H, is known as the angle of deviation ($\angle \delta$).

MATERIALS REQUIRED



A glass prism, drawing board, white paper, adhesive tape or drawing pins, pins, a measuring scale, and a protractor.

PROCEDURE



1. Fix a white sheet of paper on a drawing board. Draw a thin line XY at the middle of the paper.
2. Draw a thin line NEN' normal (perpendicular) to the line XY at point of incidence E (say). Also draw a line DE making any angle, preferably between 30° and 60° as shown in Fig. 42.2.
3. Place the prism with one of its refracting surfaces (say AB) along the line XY. Mark the boundary ABC of the glass prism holding it firmly with your hand.
4. Fix two pins P_1 and P_2 vertically, by gently pressing their heads with thumb, on line DE at a distance of about 6 cm from each other. View the images of pins P_1 and P_2 from the opposite face AC of the prism.
5. Fix two more pins P_3 and P_4 vertically such that the feet of pins P_3 and P_4 appear to be on the same straight line as the feet of the images of the pins P_1 and P_2 as viewed through the face AC of the prism.

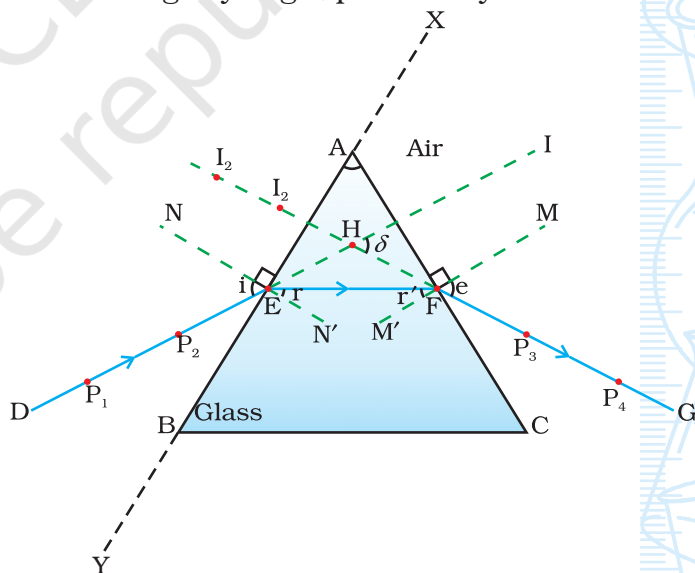

Fig. 42.2 : The images of pins P_1 and P_2 appear to be at I_1 and I_2 when viewed through the face AC of the glass prism. Rays DE, EF, and FG represent the incident, refracted and emergent rays respectively. $\angle DEN$ is the angle of incidence ($\angle i$) and $\angle FHI$ is the angle of deviation ($\angle d$)

- Remove the pins and prism. Mark the position of feet of pins P_3 and P_4 on the sheet of paper. Draw a straight line to join the points that mark the position of pins P_3 and P_4 . Extend this line so that it meets the face AC of the prism at point F. The line FG represents the path of the emergent ray.
- Extend the direction of incident ray DE till it meets the face AFC. Also extend (backwards) the emergent ray FG as shown in Fig. 42.2. These two extended lines meet at point H.
- Measure $\angle DEN$ as the angle of incidence ($\angle i$) and $\angle FHM$ as the angle of deviation ($\angle d$). Record these angles in the observation table.
- Repeat the experiment for one more angle of incidence, preferably between 30° and 60° .

OBSERVATIONS AND CALCULATIONS



Sl. No.	Angle of incidence ($\angle i$) = $\angle DEN$	Angle of deviation ($\angle \delta$) = $\angle FHI$
1.		
2.		

RESULTS AND DISCUSSION



- The path of a ray of light incident on one face of a glass prism is shown by the ray _____.
- The value of the angle of deviation for the angle of incidence _____ is _____; and for the other angle of incidence _____ is _____.

PRECAUTIONS



- While viewing the collinearity of pins and images, the eye should be kept at a distance from the pins so that all of them can be seen simultaneously. The collinearity of pins fixed on one side of the glass prism and the images of pins on the other side could also be confirmed by moving the head slightly to either side while viewing them. All the pins and images of pins would appear to move together if they are collinear.
- The pins P_1 , P_2 , P_3 and P_4 fixed on the paper may not be exactly perpendicular (or vertical) to the plane of paper. It is therefore desirable to look at the feet of the pins or their images while establishing their

collinearity. That is why the position of each pin is marked with pointed tip of the pins on the paper.

- In order to locate the direction of incident ray and refracted ray with a greater accuracy, the distance between the pins P_1 and P_2 ; and that between P_3 and P_4 should not be too short or too large. A separation of nearly 6 cm between the pins would be sufficient.
- The angle of incidence should be between 30° and 60° .

NOTE FOR THE TEACHER

- The glass prism must be triangular, bounded by rectangular refracting faces. The refracting faces should be smooth and transparent without any air bubbles or broken edges.
- A water prism can also be improvised in the lab that can be used in place of a glass prism. For this, first make two identical small equilateral triangles using sticks. Now join their vertices using three more sticks such that an outline structure of a prism is formed. Cover the sides and a base by cellophane sheets using adhesive tape. Fill it with water. The prism is ready to use. One can fill it with different liquids to show the difference in their refractive indices. (A prism can also be improvised by joining three glass sheets to make a triangular prism. Cover its base by an another glass sheet.)

QUESTIONS

- Define angle of deviation.
- List the factors on which the angle of deviation through a prism depend?
- Why does a ray of light bend towards the base when it passes through a glass prism?
- Why does white light split into different colours when passes through a glass prism?
- Why does the white light not split into different colours when it passes through a glass slab?

Experiment 43

AIM

To draw the images of an object formed by a convex lens, when placed at various positions.

THEORY

The light rays when refracted through a convex lens obey the laws of refraction. The formation of images by a convex lens can be studied by drawing ray diagrams, using the New Cartesian Sign Convention.

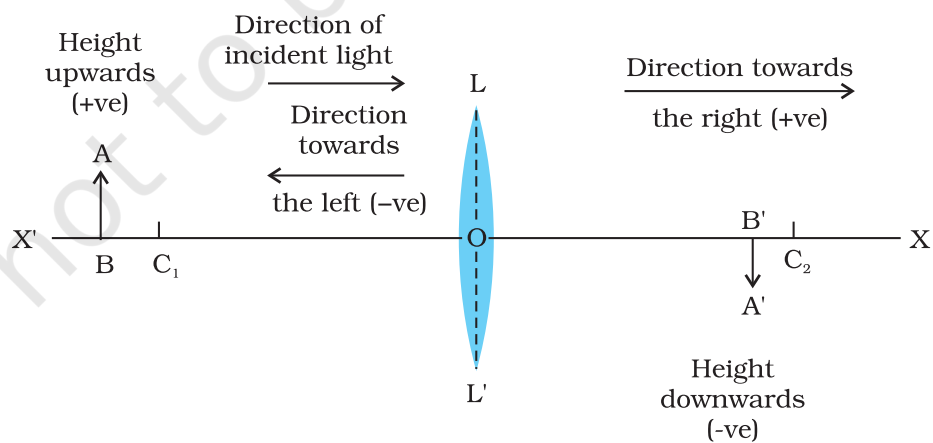

Fig. 43.1 : The New Sign Convention for a convex lens

In this convention (Fig. 43.1), the optical centre O of a convex lens LL' is considered as the origin and its principal axis as the x -axis ($X'X$) of the coordinate system. The principal axis $X'X$, is an imaginary straight line passing through the two centres of curvature C_1 and C_2 of the two spherical surfaces of the convex lens LL' . The optical centre O is a point associated with the convex lens such that a ray of light passing through O does not suffer any deviation. Here we consider the convex lens as a thin lens having a small aperture, much less than its radius of curvature.

The new cartesian sign convention can be summarised as below, and is illustrated in Fig. 43.1: (i) The object is always placed to the left of the lens. This implies that the light from the object falls on the lens from the left-hand side; (ii) All distances parallel to the principal axis are measured from the optical centre of the lens; (iii) All distances measured to the right of the origin (that is along the $+x$ -axis) are taken as positive while those measured to the left of the origin (that is along x -axis) are taken as negative; (iv) Distances measured perpendicular to and above the principal axis (that is along the $+y$ -axis) are taken as positive; and (v) Distances measured perpendicular to and below the principal axis (that is along $-y$ -axis) are taken as negative.

For an illuminated extended object AB of finite size, placed in front of a convex lens, its each small portion acts like a point source of light. An infinite number of rays of light comes from each of these point sources which could be considered for drawing the ray diagrams in order to locate the image of an object formed by a convex lens.

For the sake of clarity of ray diagrams, only two rays are considered. These are so chosen as to know their directions easily, after refraction from the convex lens LL' . The intersection of at least two refracted rays gives the position of image of the point object. Any two of the following rays can be considered for locating the image:

- (i) A ray of light from the object, parallel to the principal axis, after refraction from a convex lens, passes through the principal focus F_2 on the other side of the lens [Fig. 43.2(a)].

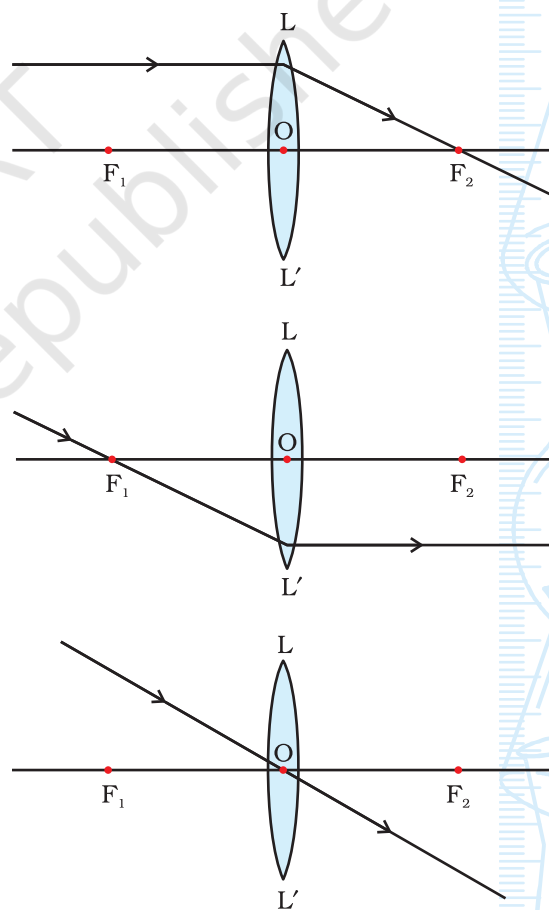

Fig. 43.2 : Any two of the above rays can be considered for locating the image formed by a convex lens

- (ii) A ray of light passing through a principal focus F_1 after refraction from a convex lens, will emerge parallel to the principal axis [Fig. 43.2(b)].
- (iii) A ray of light passing through the optical centre O of a convex lens will not suffer any deviation [Fig. 43.2(c)].

The position of the object may be (a) at infinity, (b) beyond $2F_1$, (c) at $2F_1$, (d) between F_1 and $2F_1$, (e) at focus F_1 , (f) between focus F_1 and optical centre O of the convex lens.

Neat ray diagrams can be drawn for various positions of an object in front of a convex lens, using the New Cartesian Sign Convention (Fig. 43.1) and convenient rays for locating the image (Fig. 43.2). It may be considered that the convex lens is thin and that it has a small aperture (Is it necessary?). After locating the position of the image, its nature, and size can be determined.

MATERIALS REQUIRED



Measuring scale, a drawing board, sheets of white paper, protractor, and drawing pins or adhesive tape.

PROCEDURE



1. Fix a white sheet of paper on a drawing board. Draw a thin line of about 15 - 18 cm length in the middle of the white sheet. Mark a point O at the centre of this line. Make a convex lens L about this point O . Assume O as the optical centre of the lens. Mark points F_1

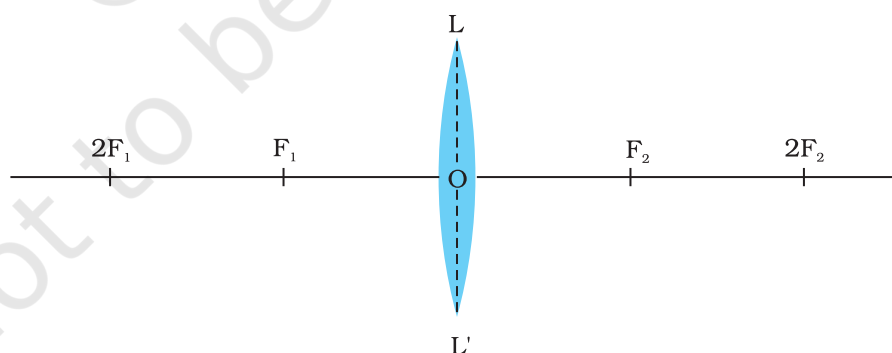

Fig. 43.3 : A convex lens and its foci

and F_2 on either side of the lens such that $OF_1 = OF_2$. (Let F_1 and F_2 be two principal foci of the lens.) Also mark points $2F_1$ and $2F_2$ on the line at double the distances OF_1 and OF_2 (Fig. 43.3).

2. Draw an object AB of suitable height h , shown to be placed at infinity as shown in Fig. 43.4(a).

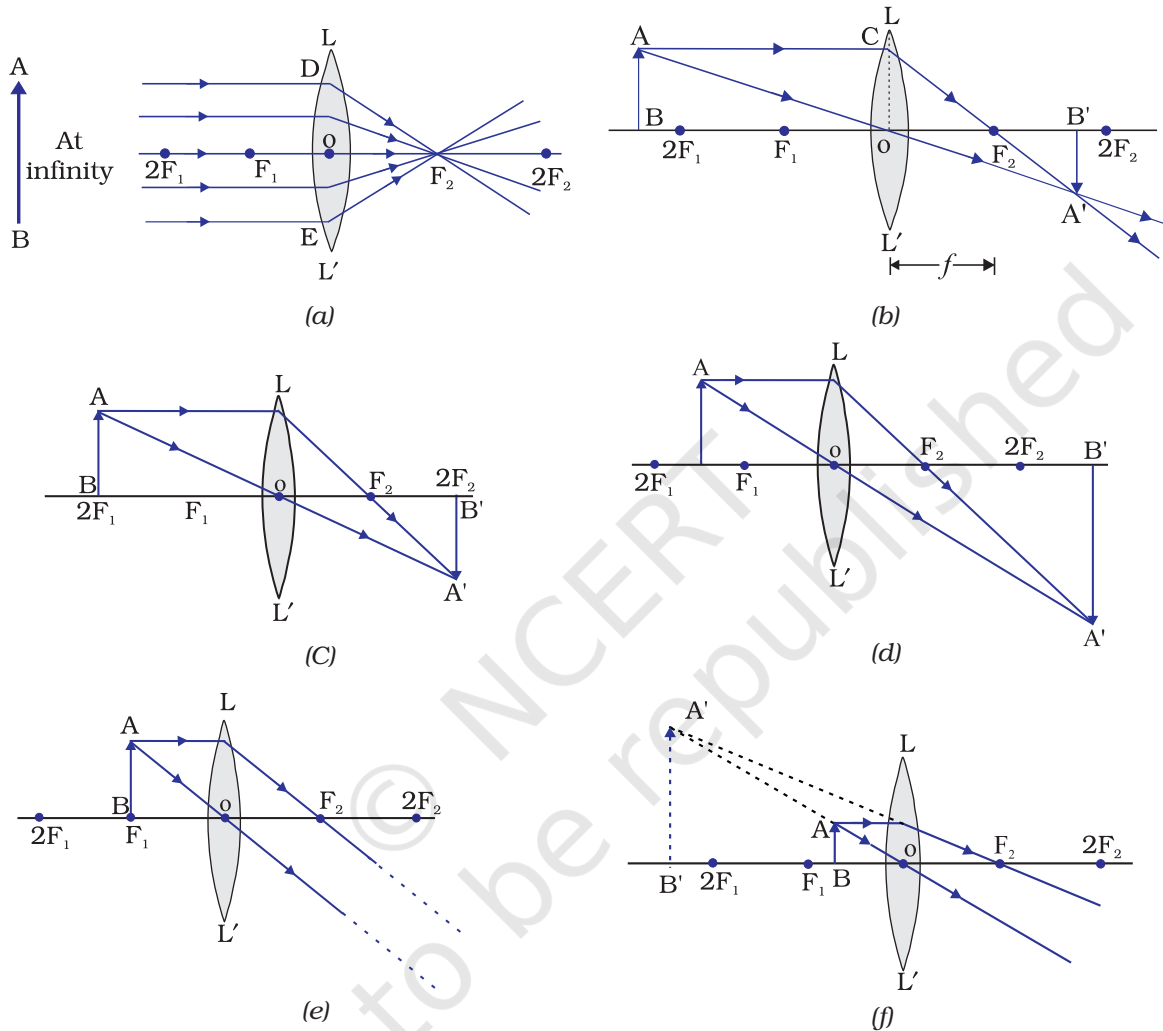

Fig. 43.4 : The position, size and the nature of the image formed by a convex lens for various positions of the object

3. Draw thin lines, representing incident rays coming from the object AB parallel to the principal axis F_1OF_2 , striking the surface of the convex lens LL' at the points of incidence D, E etc. These rays after refraction through the convex lens LL' emerge as refracted rays DF_2, EF_2 and so on. These rays intersect at the focus F_2 of the lens on the other side and a diminished image of the distant object is formed at the point F_2 , as shown in Fig. 43.4(a).

- Repeat the above steps, using the New Cartesian Sign convention and considering relevant rays for locating the image. Draw neat ray diagrams for each position of the object, as illustrated in Fig. 43.4(a) - (f).
- Measure the heights of the object AB (h) and its image A'B' (h'), respectively in all cases [Figs. 43.4(a) - (f)]. Record them in the observation table.
- Describe the nature, position and relative size of the image, formed by the convex lens, of the object placed at various positions. Tabulate the results in a convenient format or observation table.

OBSERVATIONS, RESULT AND CONCLUSION



The characteristics of image formed by a convex lens for various positions of the object [as illustrated in ray diagrams in Figs. 43.4(a) - (f)] are as follows:

Sl. No.	Ray diagram	Position of the object	Position of the image	Nature of the image	Size of the object, h (cm)	Size of the image, h' (cm)	Magnification (h'/h)
Fig. 43.4							
1.	(a)	At infinity	At focus F_2	Real			
2.	(b)	Beyond $2F_1$	Between F_2 and $2F_2$	Real and inverted			
3.	(c)	At $2F_1$	At $2F_2$	Real and inverted			
4.	(d)	Between F_1 and $2F_1$	Beyond $2F_2$	Real and inverted			
5.	(e)	At focus F_1	At infinity	Real and inverted			
6.	(f)	Between focus F_1 and optical centre O	On the same side of the convex lens as the object	Virtual and erect			

PRECAUTIONS



- Use a very sharp tipped pencil to draw thin lines to represent incident and refracted rays.
- The convex lens drawn should be thin and of small aperture. (This is required for obtaining the distinct image.)

NOTE FOR THE TEACHER

- Normally we use equiconvex lens in a school laboratory. If this lens is not equiconvex then the condition $OF_1 = OF_2$ will not hold good.
- The ray diagrams for the image formation of the object by a convex lens can also be drawn on a graph paper and measurement of the lengths h and h' of the size of the object and its image taken more conveniently.

QUESTIONS

- Sometimes, the image formed by a convex lens, of an object placed at $2F_1$ is not of the same size and at location $2F_2$ on the other side of the convex lens. What could be the possible reason(s) for such a situation?
- A ray of light is passing through the principal focus of a convex lens. How will it emerge after refraction through the lens?
- An object is placed on the left side of a lens (having 10 cm focal length) at a distance of 20 cm. What will be the sign of object distance?

Experiment 44

AIM

To determine the focal length of a thin convex lens by obtaining image of a distant object.

THEORY

The rays of light coming from a distant object such as the sun (or a distant tree or a distant building) can be considered to be parallel to each other. When a parallel beam of light falls on a convex lens, the rays, after refraction, converge at a point on its other side. This point is one of the two foci of the

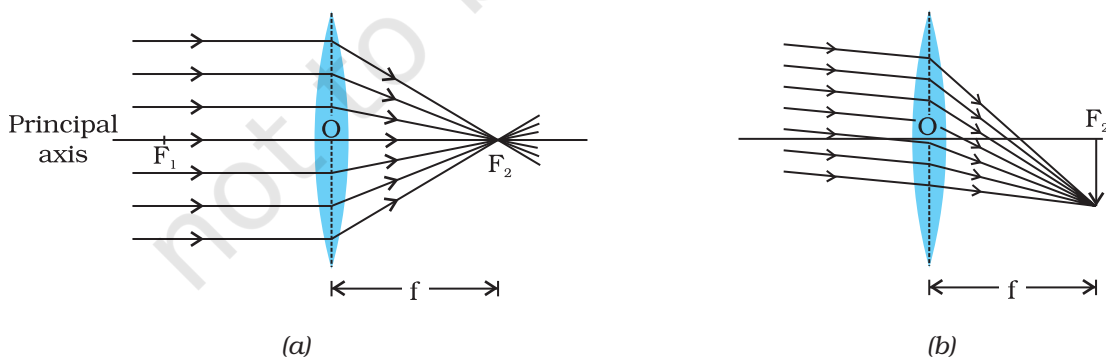

Fig. 44.1 : Image formation of a distant object by a convex lens

(a) The beam of light incident on the lens is parallel to the principal axis

(b) The beam of light incident on the convex lens is not parallel to the principal axis

lens. If the parallel beam of light comes from a distant object, a real, inverted image of very small size is formed at the focus of the lens [Fig. 44.1]. Since the image formed by the lens is real, it can be obtained on a screen. The distance between the optical centre O of the convex lens and the focus point F_1 or F_2 is its focal length. Thus, the focal length of a convex lens can be estimated by obtaining a real image of a distant object at its focus.

MATERIALS REQUIRED



A thin convex lens, a lens holder, a small screen fixed to a stand, and a measuring scale.

PROCEDURE



1. Fix a thin convex lens on a lens holder and place it on the table or platform near an open window through which sufficient sunlight enters. Turn the face of lens towards a distant object (a tree or an electricity pole or a distant building).
2. Place the screen fixed to a stand on the other side of the lens. Adjust the position of screen (by moving it back and forth in front of the convex lens) to get a sharp, clear and inverted image of the distant object on it (Fig. 44.2). A clear and bright image could also be obtained

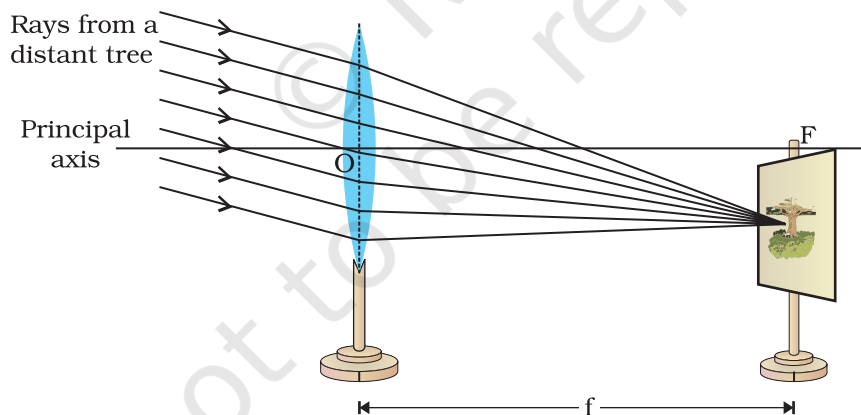

Fig. 44.2 : Determination of focal length of a thin convex lens

if the distant object, say a tree or a building, is illuminated with sunlight and the screen is kept in the shade. A bright image of the sun could also be obtained if the sunlight is made to fall directly on the lens.

3. Mark the position of the centre of the stands holding the lens and that of the screen when a sharp image of the distant object has been obtained on the screen. Measure the horizontal distance between the centre of the convex lens and the screen with the help of a measuring scale. Record your observations in the observation table.
4. Repeat the experiment two more times by obtaining the images of two different distant objects. Measure the distance between the convex lens and the screen in each case. Record them in the observation table.
5. Find the average or mean value of the focal length.

OBSERVATIONS AND CALCULATIONS



Sl. No.	Name of the distant object	Distance between the convex lens and the screen, f		Mean focal length of the convex lens, f
		(cm)	(m)	
1.				
2.				
3.				

RESULTS AND DISCUSSION



The approximate value of focal length of the given convex lens is ____ m.

PRECAUTIONS AND SOURCES OF ERROR



- The principal axis of the convex lens should be horizontal, that is, the lens should be placed vertically.
- There should be no obstacle in the path of rays of light from the distant object incident on the convex lens.
- The image of the sun formed by the lens should be focussed only on the screen. The image of sun should never be seen directly with the naked eye. Sunlight should never be focussed with a convex lens on any part of the body, paper or any inflammable materials, as it can be dangerous to do so.
- Adjust the position of convex lens such that the light rays coming from the distant object fall on the lens without any obstruction.
- In order to obtain a sharp and clear image of the distant object on the screen (or wall), it must be ensured that the distant object is well illuminated. This would allow an appreciable amount of light to fall on

the lens. This is required to produce a well illuminated and distinct image.

- In certain situations, the parallel rays of light originating from a distant object and incident on a convex lens may not be parallel to its principal axis as shown in Figs. 44.1(b) and 44.2. The image in such an event might be formed slightly away from the principal axis of the lens.
- The base of the stands of the convex lens and screen should be parallel to the measuring scale. To determine the focal length, the distance between the convex lens and the screen should be measured horizontally (placed at the focus point on the other side of the lens).

NOTE FOR THE TEACHER

- Use the thin convex lens with focal length preferably between 15 cm to 20 cm.
- A distant object does not necessarily mean a very far off object, like a building or a tree or an electricity pole. A well illuminated window or a glowing bulb at a distance of about 10 m to 15 m away, even within the science laboratory, may also be taken as a distant object.

QUESTIONS

- How will you distinguish between a convex and concave lens?
- To determine the focal length of a convex lens, a student focuses a classroom window, a distant tree and the sun on the screen. In which case will the student be closer to accurate value of focal length?
- What is the nature of an image formed by a thin convex lens for a distant object? What change do you expect if the lens were rather thick?
- You are provided with two convex lenses of same aperture and different thickness. Which one of them will be of shorter focal length?
- If we cover one half of the convex lens while focusing a distant object, in what way will it affect the image formed?
- Can this method be used to find the approximate focal length of a concave lens?
- Which type of lens is used by the watch-makers while repairing fine parts of a wrist watch?

Experiment 45

AIM

To study the formation of an image of a lighted candle by a convex lens when placed at a distance slightly more than the twice of focal length (f) from the optical centre of the lens.

THEORY

The position, nature and size of the image of an object formed by a thin convex lens can be studied, using new cartesian sign convention and drawing ray diagrams. The ray diagrams for obtaining image formed by a thin convex lens, of an object when placed at various positions are given in Experiment 43. The position, nature and size of the image formed depend on the position of the object with respect to the optical centre O of the convex lens LL' .

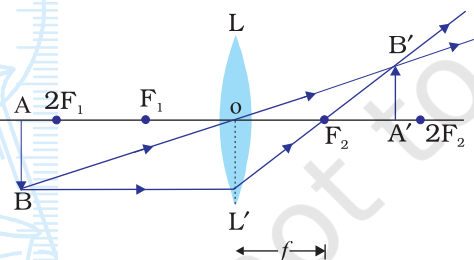

Fig. 45.1 : Formation of an image $A'B'$ formed by a thin convex lens LL' (having focal length f) of an object when placed slightly more (beyond) $2f$: A real, inverted and diminished image $A'B'$ lies between F_2 and $2F_2$. F_2 is the second principal focus on the other side of the thin convex lens

Fig. 45.1 summarises the formation of image of an object AB formed by a thin convex lens when the object is placed at slightly more than the twice the focal length (beyond $2f$) from the optical centre of a thin convex lens. A real, inverted image can be obtained on a screen. The image of the flame of a lighted candle placed beyond a distance $2f$ on one side of a convex lens can be focused on a screen on

the other side of the lens. The nature, position, and size of the image can be noted and measured from the optical centre O of the thin convex lens.

MATERIALS REQUIRED



A thin convex lens, a lens holder (or a stand), a piece of rice paper screen fixed to a stand, a meter scale, a small candle with stand, and a match box.

PROCEDURE



1. Hold a thin convex lens in hand and determine its approximate focal length f by obtaining a sharp image of a distant object (such as the sun, or a tree or an electricity pole or a building) on a wall or a screen and measuring the distance between the image and the thin convex lens.
2. Fix the thin convex lens LL' vertically in a lens holder (or stand) and place it near the middle of the table. Note and record the position (l) of the thin convex lens in the observation table.
3. Mount a small candle vertically on a stand and light it. Place it in front of the convex lens (Fig. 45.2). Adjust the height of the centre of lens nearly equal to the height of the flame of the candle. Here the flame is considered as the object AB . Measure and record the height h of the candle flame. (It is important that the flame must not flicker. This will ensure the height h of the flame uniform through out the experiment. (Switch off the fans. Perform the experiment at a dark place).

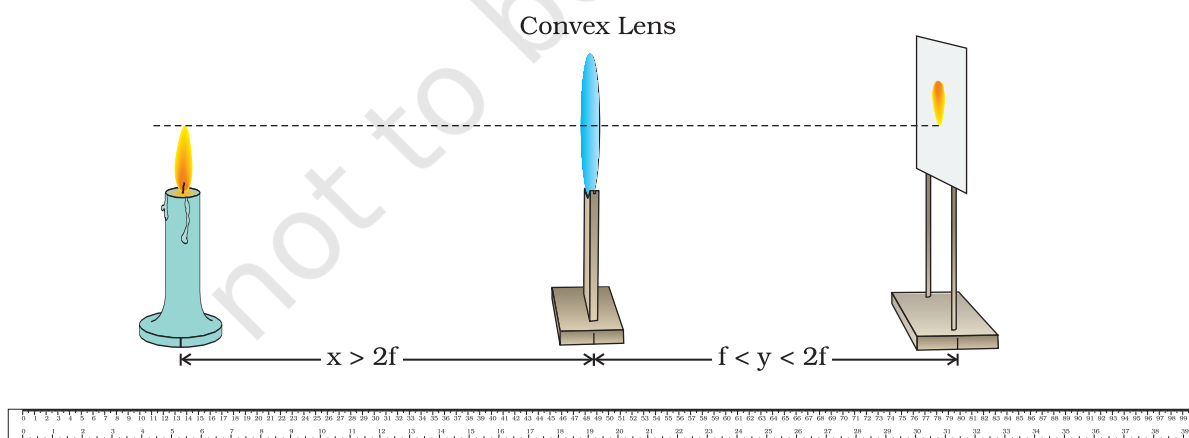

Fig. 45.2 : Locating the image of a lighted candle flame placed beyond twice the focal length of a thin convex lens

- Place the lighted candle in front of the convex lens LL' beyond twice the approximate focal length ($2f$) of the thin convex lens (Fig. 45.2). Note and record the position of the lighted candle (c). Find the distance, x (say) between the optical centre O of the lens and candle flame (object).
- Place the semi-transparent rice paper screen, fitted to a stand between, at a distance of more than the approximate focal length f on the other side of the LL' .
- To locate a sharp image $A'B'$ of the candle flame AB in the thin convex lens from the other side of the lens, adjust the position of the screen. Note and record the position of the screen, s . Find the distance between the optical centre O of the lens and the screen, y (say). Also measure and record the height h' of the image of the flame of the lighted candle obtained on the screen.
- Repeat the experiment two more times by varying x by changing the position of either the thin convex lens or the lighted candle. Locate the sharp image of the flame and record the position and height of the image in each case.

OBSERVATIONS AND CALCULATIONS



Approximate focal length of the thin convex lens, $f = \quad \text{cm}$

Height of the candle flame, $h = \quad \text{cm}$.

Nature of the image: _____ .

Sl. No.	Position of the optical centre O of the lens, l	Position of the flame, c	Position of the screen, on the other side of lens, s	Distance between O and flame $x = l \sim c$	Distance between O and image, $y = s \sim l$	Size of the image, h'	Magnification (h'/h)
	(cm)	(cm)	(cm)	(cm)	(cm)	(cm)	
1.							
2.							
3.							

RESULTS AND DISCUSSION



On the basis of observations, answer the following:

- What is the position of the screen with respect to the thin convex lens? Is this position less than, more than or equal to $2f$ in the case of a thin convex lens?

- Is the size of the image less than, more than or equal to the size of the object (candle flame)? Interpret the result in terms of magnification produced by the thin convex lens.
- What is the nature of the image obtained on the screen? Is it real or virtual? Is it inverted or erect? Is it magnified (enlarged) or diminished?

PRECAUTIONS AND SOURCES OF ERROR



- For obtaining distinct and sharp images of the candle flame, it is advised to perform this experiment in a dark room (or in shade where no direct light reaches to the working table).
- To avoid the flickering of the candle flame, perform this experiment in calm air. Switch off the fan while performing this experiment.
- While finding out the approximate value of the focal length f of the convex lens by using sunlight, do not look at the image directly with the naked eye, otherwise it might damage the eyes.
- The convex lens should be thin and of good quality transparent glass, without any scratches to obtain a distinct image.
- The aperture of the thin convex lens should be small for obtaining a sharp image.
- The eye should be placed at a distance of at least 25 cm from the image formed by the convex lens on the screen.
- The base of the stands of the convex lens and screen should be parallel to the measuring scale.

NOTE FOR THE TEACHER

- Experiment 43 titled “*To draw the images of an object formed by a convex lens when placed at various positions*” aims to learn qualitatively about the formation of images of an object and it is better to perform it before.
- A semi-transparent or rice paper screen is good to use in this experiment. A screen may also be prepared by spreading few drops of an edible oil on a paper.
- The focal length of the thin convex lens must preferably be between 15 to 20 cm.
- This method is not very accurate, but gives a quantitative description for recording the positions of the lighted candle, convex lens and the screen.

QUESTIONS

- How will you distinguish between a convex lens and a concave lens by holding in hand and looking the printed page through them.
- In what way will image of the lighted candle be affected when the experiment is performed in a bright light area and on a windy day.
- A distinct image of the lighted candle has been obtained on screen with fixed position, using a thin convex lens. Why does the image of the candle get blurred if the position of any one of them is slightly disturbed.
- What effect do you expect if the lens is thick?

Experiment 46

AIM

To study the formation of an image of a lighted candle by a convex lens when placed at a distance of $2f$ from the optical centre of the convex lens.

THEORY

The position, nature and size of the image of an object formed by a thin convex lens can be studied, using new cartesian sign convention and drawing ray diagrams. The ray diagrams for obtaining image formed by a thin convex lens, of an object when placed at various positions are given in Experiment 43. The position, nature and size of the image formed depend on the position of the object with respect to the optical centre O of the convex lens LL' .

Fig. 46.1 summarises the formation of image of an object AB formed by a thin convex lens when the object is placed at a distance of $2f$ from the optical center O of a thin convex lens.

A real, inverted image can be obtained on a screen. The image of the flame of a lighted candle formed for the above situation (Fig. 46.1) can also be focused and obtained on a screen on the other side of the lens. The nature,

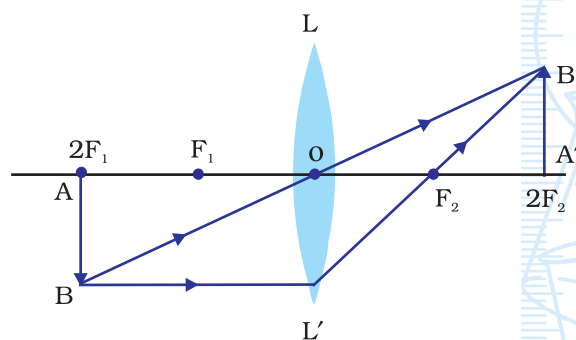

Fig. 46.1 : Formation of an image $A'B'$ formed by a thin convex lens LL' (having focal length f) of an object AB when placed at $2F_1$ at a distance of $2f$ of the thin convex lens. A real, inverted and equal size image $A'B'$ lies at $2F_2$ on the other side of the lens

position, and size of the image can be noted and measured from the optical centre O of the thin convex lens.

MATERIALS REQUIRED



A thin convex lens, a lens holder (or a stand), a small rice paper (or a semi-transparent sheet) screen fixed to a stand, a meter scale (or a ruler), a small candle with stand, and a match box.

PROCEDURE



1. Hold a thin convex lens in hand and determine its approximate focal length (f) by obtaining a sharp image of a distant object (such as the sun, or a tree or an electricity pole or a building) on a wall or a screen and measuring the distance between the image and the thin convex lens (Experiment 44).
2. Fix the thin convex lens LL' vertically in a lens holder and place it near the middle of the table. Note and record the position (O) of the optical centre of the thin convex lens in the observation table.
3. Mount a small candle vertically on a stand and light it. Place it in front of the convex lens (Fig. 46.2). Adjust the height of the centre of lens nearly equal to the height of the flame of the candle. Here the flame is considered as the object AB . Measure and record the height h of the candle flame. (It is important that the flame does not flicker. It will ensure the height h of the flame uniform through out the experiment. Switch off the fans and ensure that wind does not disturb the flame. Perform the experiment at a dark place so that the image can be seen on the screen.)

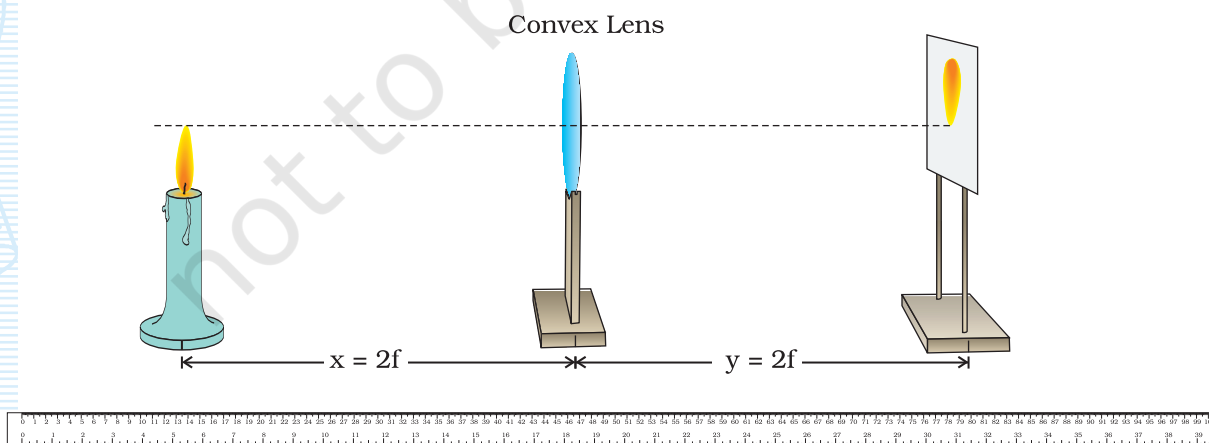

Fig. 46.2 : Locating the image $A'B'$ of a lighted candle flame AB placed at a distance $2f$ from the optical centre of a thin convex lens

- Place the lighted candle in front of the convex lens LL' at a distance equal to $2f$ from its optical centre O .
- Place the rice paper (or semi-transparent) screen fitted to a stand, at a distance equal to $2f$ from the optical centre O of the convex lens LL' on the other side of the lens (Fig. 46.2). Recall that f is approximate focal length of the thin lens.
- From Fig. 46.1, it is clear that a convex lens forms an inverted optical centre at a distance equal to $2f$ but on the other side of the lens. For realising this situation, adjust the positions of the candle flame AB and screen at equal distances from the lens on either sides of it. Now a sharp image $A'B'$ of the candle flame will form on the screen, only if the flame is placed at a distance equal to $2f$ from the optical centre O of the lens. Note and record the positions of the candle flame (c) and screen (s). Find the distance (x) between the candle and lens ($= 2f$) and the distance (y) between the lens and screen. Is the distance x equal to the distance y ?
- Measure the height h' of the image of the flame formed on the screen. Is it equal to the height of the object flame h ?
- Repeat the experiment at least two more times by changing the position of convex lens. Record observations in the observation table.

OBSERVATIONS AND CALCULATIONS



Approximate focal length of the convex lens, $f_a =$ _____ cm.

Nature of the image: _____ .

Sl. No.	Position of the optical centre O of the lens, l	Height of the candle flame, h	Position of the candle flame, c	Position of the screen on the other side of lens, s	Distance between O and flame, $x = 2f =$	Distance between O and image, $y = 2f =$	Size of the image, h'	Magnification (h'/h)
	(cm)	(cm)	(cm)	(cm)	$l \sim c$ (cm)	$s \sim l$ (cm)	(cm)	
1.								
2.								
3.								

RESULTS AND DISCUSSION



- What is the position of the screen with respect to the thin convex lens? Is this position less than, more than or equal to $2f$?
- Is the size of the image less than, more than or equal to the size of the object (candle flame)? Interpret the result, on the basis of your observations, in terms of magnification produced by the thin convex lens.
- What is the nature of the image obtained on the screen? Is it real or virtual? Is it inverted or erect? Is it magnified (enlarged) or diminished?

PRECAUTIONS AND SOURCES OF ERROR



- For obtaining distinct and sharp images of the candle flame, it is advised to perform this experiment in a dark room or at least in shade where no direct light reaches to the working table.
- To avoid the flickering of the candle flame, perform this experiment in calm air. Switch off the fan while performing this experiment.
- While finding out the approximate value of the focal length f of the convex lens by using sunlight, do not look at the image directly with the naked eye, otherwise it might damage the eyes.
- The convex lens should be thin and of good quality transparent glass, without any scratches to obtain a distinct image.
- The aperture of the thin convex lens should be small for obtaining a distinct image.
- The eye should be placed at a distance of at least 25 cm from the image formed by the convex lens on the screen.
- The base of the stands of the convex lens and screen should be parallel to the measuring scale.

NOTE FOR THE TEACHER

- In this experiment, it is suggested to use a lighted candle flame as an object. A mesh placed on a torch glass is can be another choice.
- Experiment 43 titled “*To draw the images of an object formed by a convex lens when placed at various positions*” aims to learn qualitatively about the formation of images of an object and it is better to perform it before this experiment.
- A semi-transparent rice paper screen is good to use in this experiment. A screen may also be prepared by spreading few drops of an edible oil on a paper.

- The focal length of the thin convex lens can be between 15 to 20 cm.
- This method is not very accurate, but gives a quantitative description for recording the positions of the lighted candle, convex lens and the screen.

QUESTIONS

- How will you distinguish between a convex lens and a concave lens by holding in hand and looking the printed page into them.
- In what way will be image of the lighted candle be affected when the experiment is performed in a bright light area and on a windy day.
- A distinct image of the lighted candle has been obtained on screen with fixed position, using a thin convex lens. Why does the image of the candle get blurred if the position of any one of them is slightly disturbed.
- What effect do you expect if the lens is thick?
- Why do we require a calm atmosphere to perform this experiment?

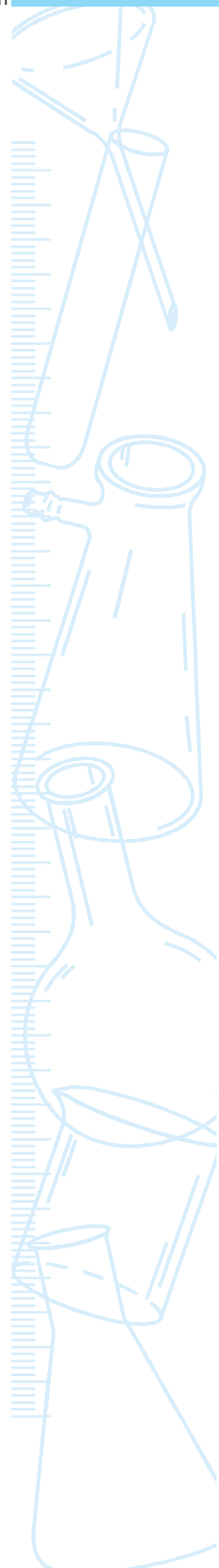

Experiment 47

AIM

To study the formation of an image of a lighted candle by a convex lens when placed at a distance less than $2f$ but more than f from the optical centre of the convex lens.

THEORY

The position, nature and size of the image of an object formed by a thin convex lens can be studied, using new cartesian sign convention and drawing ray diagrams. The ray diagrams for obtaining image formed by a thin convex lens, of an object when placed at various positions are given in Experiment 43. The position, nature and size of the image formed depend on the position of the object with respect to the optical centre O of the convex lens LL' .

Fig. 47.1 summarises the formation of image of an object AB formed by a thin convex

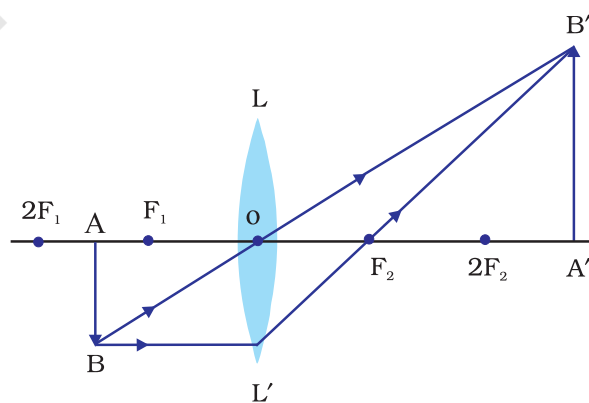

Fig. 47.1 : Formation of an image $A'B'$ formed by a thin convex lens LL' (having focal length f) of an object AB when placed between F_1 and $2F_1$ (that is at a distance less than $2f$ and more than f from the optical centre O of the thin convex lens). A real, inverted and magnified image $A'B'$ lies beyond $2F_2$ on the other side of the lens

lens when the object is placed at a distance less than $2f$ but more than f from the optical centre O of the convex lens.

A real, inverted image can be obtained on a screen. The image of the flame of a lighted candle formed for the above situation in Fig. 47.1 can also be focused on a screen on the other side of the lens. The nature, position, and size of the image can be noted and measured from the optical centre O of the thin convex lens.

MATERIALS REQUIRED



A thin convex lens, a lens holder (or a stand), a piece of rice paper (or a semi-transparent sheet) screen fixed to a stand, a meter scale (or a ruler), a small candle with stand, and a match box.

PROCEDURE



1. Hold a thin convex lens in hand and determine its approximate focal length f by obtaining a sharp image of a distant object (such as the sun, or a tree or an electricity pole or a building) on a wall or a screen and measuring the distance between the image and the thin convex lens.
2. Fix the thin convex lens LL' vertically in a lens holder (or stand) and place it near the middle of the table. Note and record the position (l) of the thin convex lens in the observation table.
3. Mount a small candle vertically on a stand and light it. Place it in front of the convex lens (Fig. 47.2). Adjust the height of the centre of lens nearly equal to the height of the flame of the candle. Here the flame is considered as the object AB . Measure and record the height h of the candle flame. (It is important that the flame does not flicker. It will ensure the height h of the flame uniform through out the

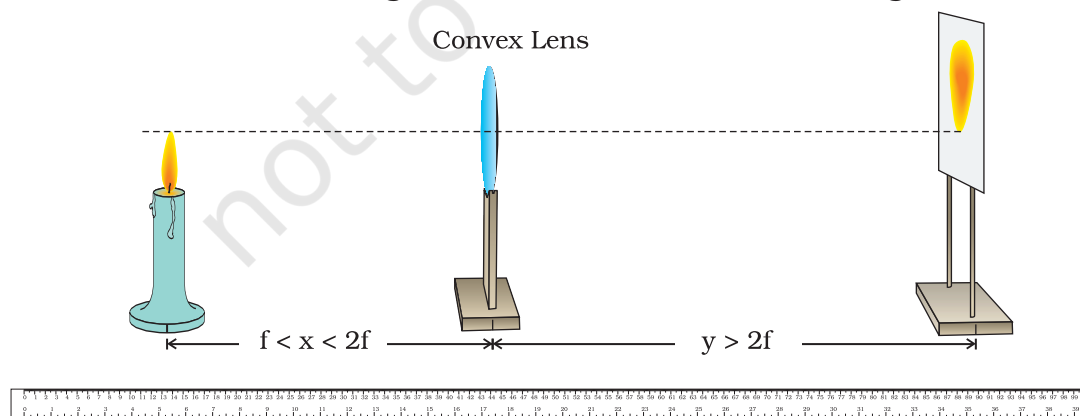

Fig. 47.2 : Locating the image of a lighted candle flame placed between $2f$ and f from the optical centre of a thin convex lens

experiment. Switch off the fans and no wind must disturb the flame. Perform the experiment at a dark place so that the image can be seen on the screen.)

- Place the lighted candle in front of the convex lens LL' at a distance between $2f$ and f from the optical centre O of the lens (Fig. 47.2). Note and record the position of the lighted candle (c). Find the distance, x (say) between the optical centre O of the lens and candle flame (object).
- Place the rice paper screen, fitted to a stand between, at a distance more than $2f$ from the optical centre of the lens on the other side of the convex lens LL' .
- To locate a sharp image $A'B'$ of the candle flame AB in the thin convex lens from the other side of the lens, adjust the position of the screen. Note and record the position, s of the screen. Find the distance between the optical centre O of the lens and the screen, y (say). Also measure and record the height h' of the image of the lighted candle obtained on the screen.
- Repeat the experiment two more times by varying distance x slightly by changing the position of either the thin convex lens or the lighted candle. Locate the sharp image of the flame and record the position and height of the image in each case.

OBSERVATIONS AND CALCULATIONS



Approximate focal length of the thin convex lens, $f =$ _____ cm

Height of the candle flame, $h =$ _____ cm.

Nature of the image: _____ .

Sl. No.	Position of the optical centre O of the lens, l (cm)	Position of the flame, c (cm)	Position of the screen, on the other side of lens, s (cm)	Distance between O and flame $x = l - c$ (cm)	Distance between O and image, $y = s - l$ (cm)	Size of the image, h' (cm)	Magnification (h'/h)
1.							
2.							
3.							

RESULTS AND DISCUSSION



On the basis of observations, answer the following:

- What is the position of the screen with respect to the thin convex lens? Is this position less than, more than or equal to $2f$?

- Is the size of the image less than, more than or equal to the size of the object (candle flame)? Interpret the result in terms of magnification produced by the convex lens.
- What is the nature of the image obtained on the screen? Is it real or virtual? Is it inverted or erect? Is it magnified (enlarged) or diminished?

PRECAUTIONS AND SOURCES OF ERROR



- For obtaining distinct and sharp images of the candle flame, it is advised to perform this experiment in a dark room or at least in shade where no direct light reaches to the working table.
- To avoid the flickering of the candle flame, perform this experiment in calm air. Switch off the fan while performing this experiment.
- While finding out the approximate value of the focal length f of the convex lens by using sunlight, do not look at the image directly with the naked eye, otherwise it might damage the eyes.
- The convex lens should be thin and of good quality transparent glass, without any scratches to obtain a distinct image.
- The aperture of the convex lens should be small for obtaining a distinct image.
- The eye should be placed at a distance of at least 25 cm from the image formed by the convex lens on the screen.
- The base of the stands of the convex lens and screen should be parallel to the measuring scale.

NOTE FOR THE TEACHER

- Experiment 43 titled “*To draw the images of an object formed by a convex lens when placed at various positions*” aims to learn qualitatively about the formation of images of an object and it is better to perform it before this experiment.
- A semi-transparent rice paper screen is good to use in this experiment. A screen may also be prepared by spreading few drops of an edible oil on a paper.
- The focal length of the thin convex lens must preferably be between 15 to 20 cm.
- This method is not very accurate, but gives a rough quantitative description for recording the positions of the lighted candle, convex lens and the screen.

QUESTIONS

- How will you distinguish between a convex lens and a concave lens by holding in hand and looking the printed page into them successively.
- A distinct image of the lighted candle has been obtained on screen with fixed position, using a thin convex lens. Why does the image of the candle get blurred if the position of any one of them is slightly disturbed.
- Why do you require a calm atmosphere to perform this experiment?
- What effect do you expect if the lens is thick?
- Why is it preferred to perform this experiment in dark or in shade?