

Chapter 27: CIRCUITS

1. “The sum of the currents into a junction equals the sum of the currents out of the junction” is a consequence of:
- A. Newton’s third law
 - B. Ohm’s law
 - C. Newton’s second law
 - D. conservation of energy
 - E. conservation of charge

ans: E

2. “The sum of the emf’s and potential differences around a closed loop equals zero” is a consequence of:
- A. Newton’s third law
 - B. Ohm’s law
 - C. Newton’s second law
 - D. conservation of energy
 - E. conservation of charge

ans: D

3. A portion of a circuit is shown, with the values of the currents given for some branches. What is the direction and value of the current i ?

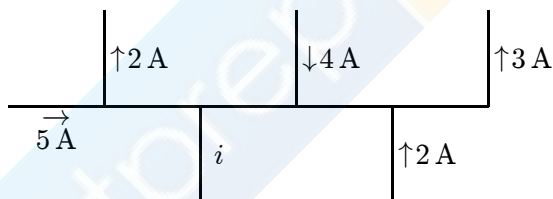

- A. ↓, 6 A
- B. ↑, 6 A
- C. ↓, 4 A
- D. ↑, 4 A
- E. ↓, 2 A

ans: A

4. Four wires meet at a junction. The first carries 4 A into the junction, the second carries 5 A out of the junction, and the third carries 2 A out of the junction. The fourth carries:
- A. 7 A out of the junction
 - B. 7 A into the junction
 - C. 3 A out of the junction
 - D. 3 A into the junction
 - E. 1 A into the junction

ans: D

5. In the context of the loop and junctions rules for electrical circuits a junction is:
- A. where a wire is connected
 - B. where a wire is connected to a battery
 - C. where only two wires are joined
 - D. where three or more wires are joined
 - E. where a wire is bent
- ans: D
6. For any circuit the number of independent equations containing emf's, resistances, and currents equals:
- A. the number of junctions
 - B. the number of junctions minus 1
 - C. the number of branches
 - D. the number of branches minus 1
 - E. the number of closed loops
- ans: C
7. If a circuit has L closed loops, B branches, and J junctions the number of independent loop equations is:
- A. $B - J + 1$
 - B. $B - J$
 - C. B
 - D. L
 - E. $L - J$
- ans: A
8. A battery is connected across a series combination of two identical resistors. If the potential difference across the terminals is V and the current in the battery is i , then:
- A. the potential difference across each resistor is V and the current in each resistor is i
 - B. the potential difference across each resistor is $V/2$ and the current in each resistor is $i/2$
 - C. the potential difference across each resistor is V and the current in each resistor is $i/2$
 - D. the potential difference across each resistor is $V/2$ and the current in each resistor is i
 - E. none of the above are true
- ans: D
9. A battery is connected across a parallel combination of two identical resistors. If the potential difference across the terminals is V and the current in the battery is i , then:
- A. the potential difference across each resistor is V and the current in each resistor is i
 - B. the potential difference across each resistor is $V/2$ and the current in each resistor is $i/2$
 - C. the potential difference across each resistor is V and the current in each resistor is $i/2$
 - D. the potential difference across each resistor is $V/2$ and the current in each resistor is i
 - E. none of the above are true
- ans: C

10. A total resistance of $3.0\ \Omega$ is to be produced by combining an unknown resistor R with a $12\ \Omega$ resistor. What is the value
- A. $4.0\ \Omega$, parallel
 - B. $4.0\ \Omega$, series
 - C. $2.4\ \Omega$, parallel
 - D. $2.4\ \Omega$, series
 - E. $9.0\ \Omega$, series
- ans: A
11. By using only two resistors, R_1 and R_2 , a student is able to obtain resistances of $3\ \Omega$, $4\ \Omega$, $12\ \Omega$, and $16\ \Omega$. The values of R_1 and R_2 (in ohms) are:
- A. 3, 4
 - B. 2, 12
 - C. 3, 16
 - D. 4, 12
 - E. 4, 16
- ans: D
12. Four $20\text{-}\Omega$ resistors are connected in parallel and the combination is connected to a 20-V emf device. The current in the device is:
- A. $0.25\ \text{A}$
 - B. $1.0\ \text{A}$
 - C. $4.0\ \text{A}$
 - D. $5.0\ \text{A}$
 - E. $100\ \text{A}$
- ans: C
13. Four $20\text{-}\Omega$ resistors are connected in parallel and the combination is connected to a 20-V emf device. The current in any one of the resistors is:
- A. $0.25\ \text{A}$
 - B. $1.0\ \text{A}$
 - C. $4.0\ \text{A}$
 - D. $5.0\ \text{A}$
 - E. $100\ \text{A}$
- ans: B
14. Four $20\text{-}\Omega$ resistors are connected in series and the combination is connected to a 20-V emf device. The current in any one of the resistors is:
- A. $0.25\ \text{A}$
 - B. $1.0\ \text{A}$
 - C. $4.0\ \text{A}$
 - D. $5.0\ \text{A}$
 - E. $100\ \text{A}$
- ans: A

15. Four $20\text{-}\Omega$ resistors are connected in series and the combination is connected to a 20-V emf device. The potential difference across the combination is:
- A. 1 V
 - B. 4 V
 - C. 5 V
 - D. 20 V
 - E. 80 V
- ans: C
16. Nine identical wires, each of diameter d and length L , are connected in parallel. The combination has the same resistance as a single similar wire of length L but whose diameter is:
- A. $3d$
 - B. $9d$
 - C. $d/3$
 - D. $d/9$
 - E. $d/81$
- ans: A
17. Nine identical wires, each of diameter d and length L , are connected in series. The combination has the same resistance as a single similar wire of length L but whose diameter is:
- A. $3d$
 - B. $9d$
 - C. $d/3$
 - D. $d/9$
 - E. $d/81$
- ans: C
18. Two wires made of the same material have the same lengths but different diameters. They are connected in parallel to a battery. The quantity that is NOT the same for the wires is:
- A. the end-to-end potential difference
 - B. the current
 - C. the current density
 - D. the electric field
 - E. the electron drift velocity
- ans: B
19. Two wires made of the same material have the same lengths but different diameters. They are connected in series to a battery. The quantity that is the same for the wires is:
- A. the end-to-end potential difference
 - B. the current
 - C. the current density
 - D. the electric field
 - E. the electron drift velocity
- ans: B

20. The equivalent resistance between points 1 and 2 of the circuit shown is:

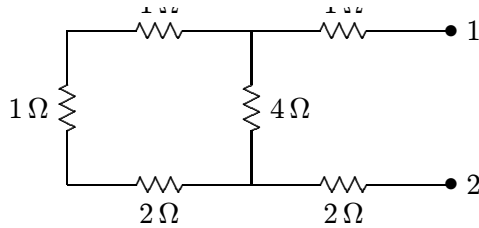

- A. 3Ω
- B. 4Ω
- C. 5Ω
- D. 6Ω
- E. 7Ω

ans: C

21. Each of the resistors in the diagram has a resistance of 12Ω . The resistance of the entire circuit is:

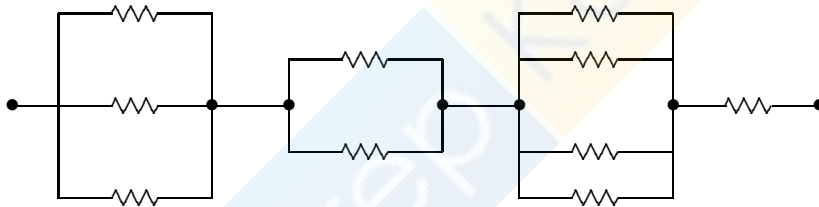

- A. 5.76Ω
- B. 25Ω
- C. 48Ω
- D. 120Ω
- E. none of these

ans: B

22. The resistance of resistor 1 is twice the resistance of resistor 2. The two are connected in parallel and a potential difference is maintained across the combination. Then:

- A. the current in 1 is twice that in 2
- B. the current in 1 is half that in 2
- C. the potential difference across 1 is twice that across 2
- D. the potential difference across 1 is half that across 2
- E. none of the above are true

ans: B

23. The resistance of resistor 1 is twice the resistance of resistor 2. The two are connected in series and a potential difference
- A. the current in 1 is twice that in 2
 - B. the current in 1 is half that in 2
 - C. the potential difference across 1 is twice that across 2
 - D. the potential difference across 1 is half that across 2
 - E. none of the above are true
- ans: C
24. Resistor 1 has twice the resistance of resistor 2. The two are connected in series and a potential difference is maintained across the combination. The rate of thermal energy generation in 1 is:
- A. the same as that in 2
 - B. twice that in 2
 - C. half that in 2
 - D. four times that in 2
 - E. one-fourth that in 2
- ans: B
25. Resistor 1 has twice the resistance of resistor 2. The two are connected in parallel and a potential difference is maintained across the combination. The rate of thermal energy generation in 1 is:
- A. the same as that in 2
 - B. twice that in 2
 - C. half that in 2
 - D. four times that in 2
 - E. one-fourth that in 2
- ans: C
26. The emf of a battery is equal to its terminal potential difference:
- A. under all conditions
 - B. only when the battery is being charged
 - C. only when a large current is in the battery
 - D. only when there is no current in the battery
 - E. under no conditions
- ans: D
27. The terminal potential difference of a battery is less than its emf:
- A. under all conditions
 - B. only when the battery is being charged
 - C. only when the battery is being discharged
 - D. only when there is no current in the battery
 - E. under no conditions
- ans: C

28. A battery has an emf of 9 V and an internal resistance of $2\ \Omega$. If the potential difference across its terminals is greater than
- it must be connected across a large external resistance
 - it must be connected across a small external resistance
 - the current must be out of the positive terminal
 - the current must be out of the negative terminal
 - the current must be zero

ans: D

29. A battery with an emf of 24 V is connected to a $6\text{-}\Omega$ resistor. As a result, current of 3 A exists in the resistor. The terminal potential difference of the battery is:
- 0
 - 6 V
 - 12 V
 - 18 V
 - 24 V

ans: D

30. In the diagram $R_1 > R_2 > R_3$. Rank the three resistors according to the current in them, least to greatest.

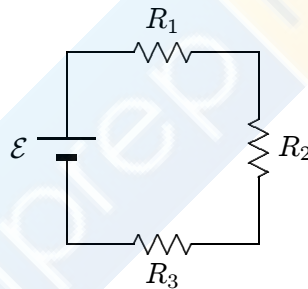

- 1, 2, 3
- 3, 2, 1
- 1, 3, 2
- 3, 1, 3
- All are the same

ans: E

31. Resistances of $2.0\ \Omega$, $4.0\ \Omega$, and $6.0\ \Omega$ and a 24-V emf device are all in parallel. The current in the $2.0\text{-}\Omega$ resistor is:
- 12 A
 - 4.0 A
 - 2.4 A
 - 2.0 A
 - 0.50 A

ans: A

32. Resistances of $2.0\ \Omega$, $4.0\ \Omega$, and $6.0\ \Omega$ and a 24-V emf device are all in series. The potential difference across the $2.0\text{-}\Omega$
- A. 4 V
 - B. 8 V
 - C. 12 V
 - D. 24 V
 - E. 48 V
- ans: A

33. A battery with an emf of 12 V and an internal resistance of $1\ \Omega$ is used to charge a battery with an emf of 10 V and an internal resistance of $1\ \Omega$. The current in the circuit is:
- A. 1 A
 - B. 2 A
 - C. 4 A
 - D. 11 A
 - E. 22 A
- ans: A

34. In the diagram, the current in the $3\text{-}\Omega$ resistor is 4 A. The potential difference between points 1 and 2 is:

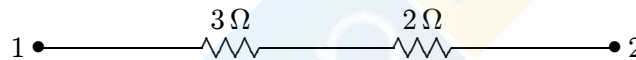

- A. 0.75 V
 - B. 0.8 V
 - C. 1.25 V
 - D. 12 V
 - E. 20 V
- ans: E
35. The current in the $5.0\text{-}\Omega$ resistor in the circuit shown is:

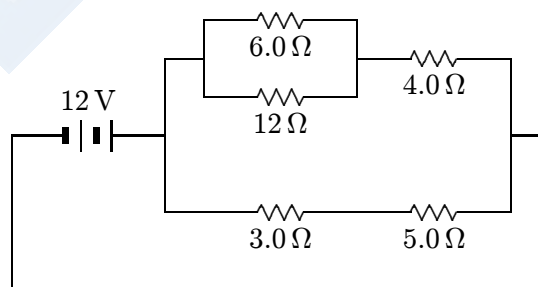

- A. 0.42 A
 - B. 0.67 A
 - C. 1.5 A
 - D. 2.4 A
 - E. 3.0 A
- ans: C

36. A $3\text{-}\Omega$ and a $1.5\text{-}\Omega$ resistor are wired in parallel and the combination is wired in series to a $4\text{-}\Omega$ resistor and a 10-V emf de
- A. 0.33 A
 - B. 0.67 A
 - C. 2.0 A
 - D. 3.3 A
 - E. 6.7 A
- ans: B
37. A $3\text{-}\Omega$ and a $1.5\text{-}\Omega$ resistor are wired in parallel and the combination is wired in series to a $4\text{-}\Omega$ resistor and a 10-V emf device. The potential difference across the $3\text{-}\Omega$ resistor is:
- A. 2.0 V
 - B. 6.0 V
 - C. 8.0 V
 - D. 10 V
 - E. 12 V
- ans: A
38. Two identical batteries, each with an emf of 18 V and an internal resistance of $1\ \Omega$, are wired in parallel by connecting their positive terminals together and connecting their negative terminals together. The combination is then wired across a $4\text{-}\Omega$ resistor. The current in the $4\text{-}\Omega$ resistor is:
- A. 1.0 A
 - B. 2.0 A
 - C. 4.0 A
 - D. 3.6 A
 - E. 7.2 A
- ans: C
39. Two identical batteries, each with an emf of 18 V and an internal resistance of $1\ \Omega$, are wired in parallel by connecting their positive terminals together and connecting their negative terminals together. The combination is then wired across a $4\text{-}\Omega$ resistor. The current in each battery is:
- A. 1.0 A
 - B. 2.0 A
 - C. 4.0 A
 - D. 3.6 A
 - E. 7.2 A
- ans: B

40. Two identical batteries, each with an emf of 18 V and an internal resistance of $1\ \Omega$, are wired in parallel by connecting their terminals together. The combination is then wired across a $4\ \Omega$ resistor. The potential difference across the $4\ \Omega$ resistor is:
- A. 4.0 V
 - B. 8.0 V
 - C. 14 V
 - D. 16 V
 - E. 29 V

ans: D

41. In the diagrams, all light bulbs are identical and all emf devices are identical. In which circuit (A, B, C, D, E) will the bulbs glow with the same brightness as in circuit X?

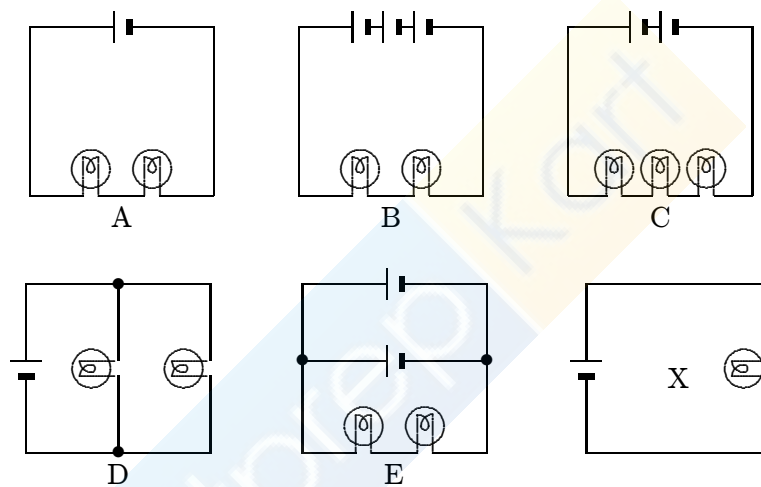

ans: D

42. In the diagrams, all light bulbs are identical and all emf devices are identical. In which circuit (A, B, C, D, E) will the bulbs be dimmest?

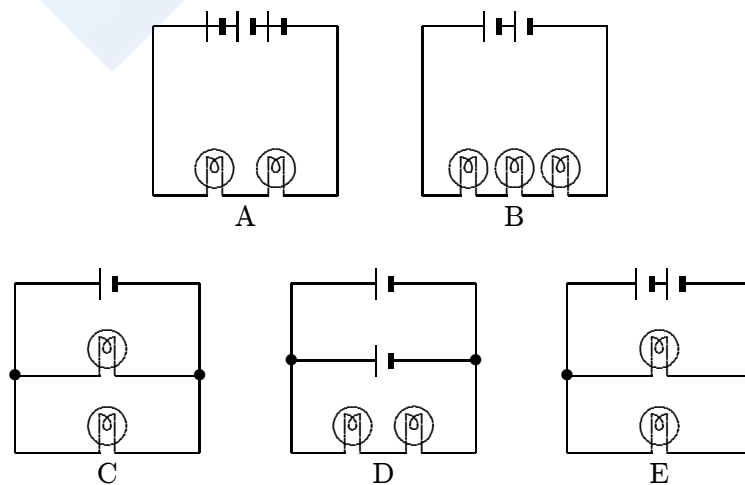

ans: D

43. A 120-V power line is protected by a 15-A fuse. What is the maximum number of “120 V, 500 W” light bulbs that can
- A. 1
 - B. 2
 - C. 3
 - D. 4
 - E. 5

ans: C

44. Two 110-V light bulbs, one “25 W” and the other “100 W”, are connected in series to a 110 V source. Then:
- A. the current in the 100-W bulb is greater than that in the 25-W bulb
 - B. the current in the 100-W bulb is less than that in the 25-W bulb
 - C. both bulbs will light with equal brightness
 - D. each bulb will have a potential difference of 55 V
 - E. none of the above

ans: E

45. A resistor with resistance R_1 and a resistor with resistance R_2 are connected in parallel to an ideal battery with emf \mathcal{E} . The rate of thermal energy generation in the resistor with resistance R_1 is:
- A. \mathcal{E}^2/R_1
 - B. $\mathcal{E}^2 R_1/(R_1 + R_2)^2$
 - C. $\mathcal{E}^2/(R_1 + R_2)$
 - D. \mathcal{E}^2/R_2
 - E. $\mathcal{E}^2 R_1/R_2^2$

ans: A

46. In an antique automobile, a 6-V battery supplies a total of 48 W to two identical headlights in parallel. The resistance (in ohms) of each bulb is:
- A. 0.67
 - B. 1.5
 - C. 3
 - D. 4
 - E. 8

ans: B

47. Resistor 1 has twice the resistance of resistor 2. They are connected in parallel to a battery. The ratio of the thermal energy generation rate in 1 to that in 2 is:
- A. 1 : 4
 - B. 1 : 2
 - C. 1 : 1
 - D. 2 : 1
 - E. 4 : 1

ans: B

48. A series circuit consists of a battery with internal resistance r and an external resistor R . If these two resistances are compared, the ratio of the external resistance R to the internal resistance r is:
- the same as by R
 - half that by R
 - twice that by R
 - one-third that by R
 - unknown unless the emf is given

ans: A

49. The positive terminals of two batteries with emf's of \mathcal{E}_1 and \mathcal{E}_2 , respectively, are connected together. Here $\mathcal{E}_2 > \mathcal{E}_1$. The circuit is completed by connecting the negative terminals. If each battery has an internal resistance r , the rate with which electrical energy is converted to chemical energy in the smaller battery is:

- \mathcal{E}_1^2/r
- $\mathcal{E}_1^2/2r$
- $(\mathcal{E}_2 - \mathcal{E}_1)\mathcal{E}_1/r$
- $(\mathcal{E}_2 - \mathcal{E}_1)\mathcal{E}_1/2r$
- $\mathcal{E}_2^2/2r$

ans: D

50. In the figure, voltmeter V_1 reads 600 V, voltmeter V_2 reads 580 V, and ammeter A reads 100 A. The power wasted in the transmission line connecting the power house to the consumer is:

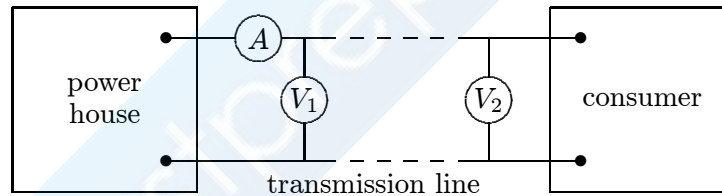

- 1 kW
- 2 kW
- 58 kW
- 59 kW
- 60 kW

ans: B

51. The circuit shown was wired for the purpose of measuring the resistance of the lamp L. Inspection shows that:

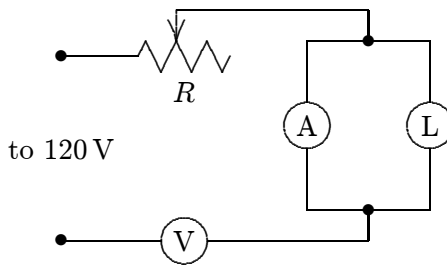

- A. voltmeter V and rheostat R should be interchanged
 - B. the circuit is satisfactory
 - C. the ammeter A should be in parallel with R, not L
 - D. the meters, V and A, should be interchanged
 - E. L and V should be interchanged
- ans: D
52. When switch S is open, the ammeter in the circuit shown reads 2.0 A. When S is closed, the ammeter reading:

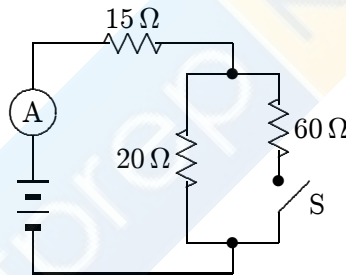

- A. increases slightly
 - B. remains the same
 - C. decreases slightly
 - D. doubles
 - E. halves
- ans: A
53. A certain galvanometer has a resistance of $100\ \Omega$ and requires 1 mA for full scale deflection. To make this into a voltmeter reading 1 V full scale, connect a resistance of:
- A. $1000\ \Omega$ in parallel
 - B. $900\ \Omega$ in series
 - C. $1000\ \Omega$ in series
 - D. $10\ \Omega$ in parallel
 - E. $0.1\ \Omega$ in series
- ans: B

54. To make a galvanometer into an ammeter, connect:
- A. a high resistance in parallel
 - B. a high resistance in series
 - C. a low resistance in series
 - D. a low resistance in parallel
 - E. a source of emf in series
- ans: D
55. A certain voltmeter has an internal resistance of $10,000\ \Omega$ and a range from 0 to 100 V. To give it a range from 0 to 1000 V, one should connect:
- A. $100,000\ \Omega$ in series
 - B. $100,000\ \Omega$ in parallel
 - C. $1000\ \Omega$ in series
 - D. $1000\ \Omega$ in parallel
 - E. $90,000\ \Omega$ in series
- ans: E
56. A certain ammeter has an internal resistance of $1\ \Omega$ and a range from 0 to 50 mA. To make its range from 0 to 5 A, use:
- A. a series resistance of $99\ \Omega$
 - B. an extremely large (say $10^6\ \Omega$) series resistance
 - C. a resistance of $99\ \Omega$ in parallel
 - D. a resistance of $1/99\ \Omega$ in parallel
 - E. a resistance of $1/1000\ \Omega$ in parallel
- ans: D
57. A galvanometer has an internal resistance of $12\ \Omega$ and requires 0.01 A for full scale deflection. To convert it to a voltmeter reading 3 V full scale, one must use a series resistance of:
- A. $102\ \Omega$
 - B. $288\ \Omega$
 - C. $300\ \Omega$
 - D. $360\ \Omega$
 - E. $412\ \Omega$
- ans: B
58. A certain voltmeter has an internal resistance of $10,000\ \Omega$ and a range from 0 to 12 V. To extend its range to 120 V, use a series resistance of:
- A. $1,111\ \Omega$
 - B. $90,000\ \Omega$
 - C. $100,000\ \Omega$
 - D. $108,000\ \Omega$
 - E. $120,000\ \Omega$
- ans: B

59. Four circuits have the form shown in the diagram. The capacitor is initially uncharged and the switch S is open.

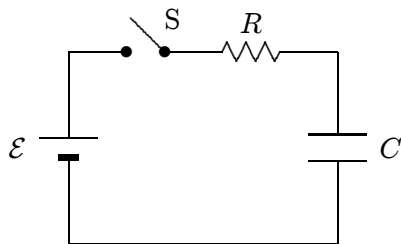

The values of the emf \mathcal{E} , resistance R , and capacitance C for each of the circuits are

circuit 1: $\mathcal{E} = 18 \text{ V}$, $R = 3 \Omega$, $C = 1 \mu\text{F}$

circuit 2: $\mathcal{E} = 18 \text{ V}$, $R = 6 \Omega$, $C = 9 \mu\text{F}$

circuit 3: $\mathcal{E} = 12 \text{ V}$, $R = 1 \Omega$, $C = 7 \mu\text{F}$

circuit 4: $\mathcal{E} = 10 \text{ V}$, $R = 5 \Omega$, $C = 7 \mu\text{F}$

Rank the circuits according to the current just after switch S is closed least to greatest.

- A. 1, 2, 3, 4
- B. 4, 3, 2, 1
- C. 4, 2, 3, 1
- D. 4, 2, 1, 3
- E. 3, 1, 2, 4

ans: D

60. Four circuits have the form shown in the diagram. The capacitor is initially uncharged and the switch S is open.

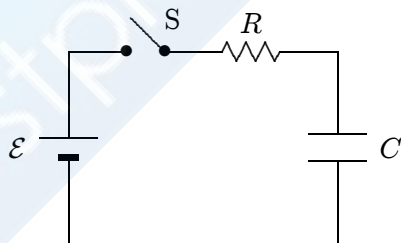

The values of the emf \mathcal{E} , resistance R , and capacitance C for each of the circuits are

circuit 1: $\mathcal{E} = 18 \text{ V}$, $R = 3 \Omega$, $C = 1 \mu\text{F}$

circuit 2: $\mathcal{E} = 18 \text{ V}$, $R = 6 \Omega$, $C = 9 \mu\text{F}$

circuit 3: $\mathcal{E} = 12 \text{ V}$, $R = 1 \Omega$, $C = 7 \mu\text{F}$

circuit 4: $\mathcal{E} = 10 \text{ V}$, $R = 5 \Omega$, $C = 7 \mu\text{F}$

Rank the circuits according to the time after switch S is closed for the capacitors to reach half their final charges, least to greatest.

- A. 1, 2, 3, 4
- B. 4, 3, 2, 1
- C. 1, 3, 4, 2
- D. 1 and 2 tied, then 4, 3
- E. 4, 3, then 1 and 2 tied

ans: C

61. The time constant RC has units of:

- A. second/farad
- B. second/ohm
- C. 1/second
- D. second/watt
- E. none of these

ans: E

62. In the circuit shown, both resistors have the same value R . Suppose switch S is initially closed. When it is then opened, the circuit has a time constant τ_a . Conversely, suppose S is initially open. When it is then closed, the circuit has a time constant τ_b . The ratio τ_a/τ_b is:

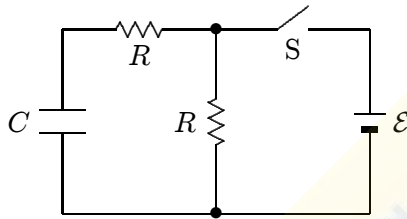

- A. 1
- B. 2
- C. 0.5
- D. 0.667
- E. 1.5

ans: B

63. In the circuit shown, the capacitor is initially uncharged. At time $t = 0$, switch S is closed. If τ denotes the time constant, the approximate current through the 3Ω resistor when $t = \tau/10$ is:

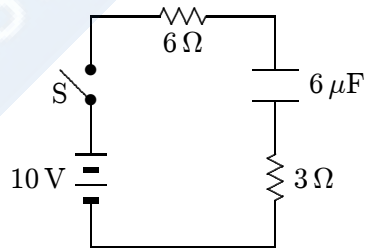

- A. 0.38 A
- B. 0.50 A
- C. 0.75 A
- D. 1.0 A
- E. 1.5 A

ans: D

64. Suppose the current charging a capacitor is kept constant. Which graph below correctly gives the potential difference V

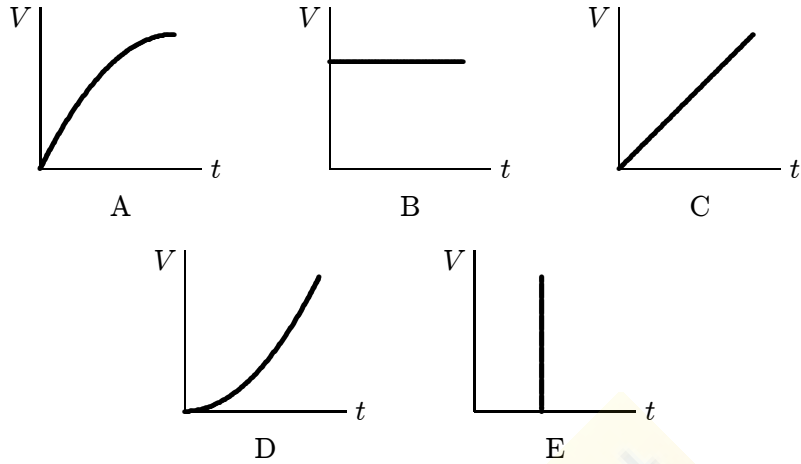

ans: C

65. A charged capacitor is being discharged through a resistor. At the end of one time constant the charge has been reduced by $(1 - 1/e) = 63\%$ of its initial value. At the end of two time constants the charge has been reduced by what percent of its initial value?
- 82%
 - 86%
 - 100%
 - Between 90% and 100%
 - Need to know more data to answer the question

ans: B

66. An initially uncharged capacitor C is connected in series with resistor R . This combination is then connected to a battery of emf V_0 . Sufficient time elapses so that a steady state is reached. Which of the following statements is NOT true?
- The time constant is independent of V_0
 - The final charge on C is independent of R
 - The total thermal energy generated by R is independent of R
 - The total thermal energy generated by R is independent of V_0
 - The initial current (just after the battery was connected) is independent of C

ans: C

67. A certain capacitor, in series with a resistor, is being charged. At the end of 10 ms its charge is half the final value. The time constant for the process is about:
- 0.43 ms
 - 2.3 ms
 - 6.9 ms
 - 10 ms
 - 14 ms

ans: E

68. A certain capacitor, in series with a $720\text{-}\Omega$ resistor, is being charged. At the end of 10 ms its charge is half the final value

- A. $9.6\ \mu\text{F}$
- B. $14\ \mu\text{F}$
- C. $20\ \mu\text{F}$
- D. $7.2\ \text{F}$
- E. $10\ \text{F}$

ans: C

69. In the capacitor discharge formula $q = q_0 e^{-t/RC}$ the symbol t represents:

- A. the time constant
- B. the time it takes for C to lose the fraction $1/e$ of its initial charge
- C. the time it takes for C to lose the fraction $(1 - 1/e)$ of its initial charge
- D. the time it takes for C to lose essentially all of its initial charge
- E. none of the above

ans: E

