

# COMMUNICATION SYSTEMS

The term 'communication' refers to sending, receiving and processing of information electronically. System is the setup to transmit information.

## Basic terminology used in electronic communication system

- (i) *Transducer*: Any device that converts one form of energy into another can be termed as a transducer. An electrical transducer may be defined as a device that converts some physical variable (pressure, displacement, force, temperature, etc) into corresponding variations in the electrical signal at its output.
- (ii) *Signal*: Information converted in electrical form and suitable for transmission is called a signal. Signals can be either *analog* or *digital*.
- (iii) *Noise*: Noise refers to the unwanted signals that tend to disturb the transmission and processing of message signals in a communication system. The source generating the noise may be located inside or outside the system.
- (iv) *Transmitter*: A transmitter processes the incoming message signal so as to make it suitable for transmission through a channel and subsequent reception.
- (v) *Receiver*: A receiver extracts the desired message signals from the received signals at the channel output.
- (vi) *Attenuation*: The loss of strength of a signal while propagating through a medium is known as attenuation.
- (vii) *Amplification*: It is the process of *increasing the amplitude* (and consequently the strength) of a signal using an electronic circuit called the amplifier. Amplification is necessary to compensate for the attenuation of the signal in communication systems. Amplification is done at a place between the source and the destination wherever signal strength becomes weaker than the required strength.
- (viii) *Range*: It is the largest distance between a source and a destination up-to which the signal is received with sufficient strength.
- (ix) *Band width* : Bandwidth refers to the frequency range over which an equipment operates or the portion of the spectrum occupied
- (x) *Modulation*: The original low frequency message/information signal cannot be transmitted to long distances, therefore information contained in low frequency signal is super imposed on high frequency wave which acts as a carrier of information. This process is called modulation
- (xi) *Demodulation*: The process of retrieval of information from the carrier wave at the receiver is termed demodulation. This is the reverse process of modulation.
- (xii) *Repeater*: A repeater is a combination of a receiver and a transmitter. A repeater picks up the signal from the transmitter change in carrier frequency. Repeaters are used to extend the range of a communication system. Communication satellite is essentially a repeater station in space.

### Analog Signal and Digital signal:

*Analog signals* are continuous variations of voltage or current. *They are essentially single-valued functions of time.*

Sine wave is a fundamental analog signal. Sound and picture signals in TV are analog in nature.

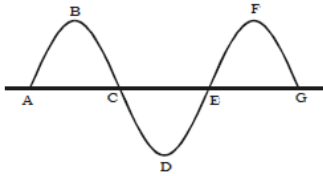

*Digital signals* are those which can take only discrete stepwise values. Binary system that is extensively used in digital electronics employs just two levels of a signal. '0' corresponds to a low level and '1' corresponds to a high level of voltage/ current.

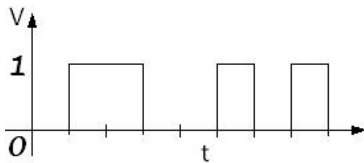

One can show that this rectangular wave can be composed into a superposition of sinusoidal waves of frequencies  $\nu_0, 2\nu_0, 3\nu_0, 4\nu_0 \dots n\nu_0$  where  $n$  is an integer extending to infinity and  $\nu_0 = 1/T_0$ . The fundamental ( $\nu_0$ ), fundamental ( $\nu_0$ ) + second harmonic ( $2\nu_0$ ), and fundamental ( $\nu_0$ ) + second harmonic ( $2\nu_0$ ) + third harmonic ( $3\nu_0$ ), are shown in the same figure to illustrate this fact.

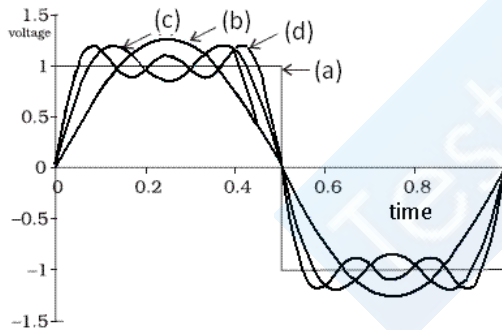

- (a) rectangular wave
- (b) Fundamental  $\nu_0$
- (c) Fundamental  $\nu_0$  + Second harmonic  $2\nu_0$
- (d) Fundamental  $\nu_0$  + Second harmonic  $2\nu_0$  + Third harmonics  $3\nu_0$

It is clear that to reproduce the rectangular wave shape exactly we need to superimpose all the harmonics  $\nu_0, 2\nu_0, 3\nu_0, 4\nu_0 \dots$ , which implies an infinite bandwidth.

However, for practical purposes, the contribution from higher harmonics can be neglected. This is so because the higher the harmonic, less is its contribution to the wave form.

There are several coding schemes useful for digital communication.

They employ suitable combinations of number systems such as the binary coded decimal (BCD).

American Standard Code for Information Interchange (ASCII) is a universally popular digital code to represent numbers, letters and certain characters.

### Bandwidth of signals

In a communication system, the message signal can be voice, music, picture or computer data. Each of these signals has different ranges of frequencies.

The type of communication system needed for a given signal depends on the band of frequencies which is considered essential for the communication process. For speech signals, frequency range 300 Hz to 3100 Hz is considered adequate.

Therefore speech signal requires a bandwidth of 2800 Hz (3100 Hz– 300 Hz) for commercial telephonic communication.

To transmit music, an approximate bandwidth of 20 kHz is required because of the high frequencies produced by the musical instruments. The audible range of frequencies extends from 20 Hz to 20 kHz.

Video signals for transmission of pictures require about 4.2 MHz of bandwidth.

A TV signal contains both voice and picture and is usually allocated 6 MHz of bandwidth for transmission.

### Bandwidth of transmission medium

Different types of transmission media offer different bandwidths. The commonly used transmission media are wire, free space and fiber optic cable. Coaxial cable is a widely used wire medium, which offers a bandwidth of approximately 750 MHz. Such cables are normally operated below 18 GHz.

Communication through free space using radio waves takes place over a very wide range of frequencies: from a few hundreds of kHz to a few GHz.

Optical communication using fibers is performed in the frequency range of 1 THz to 1000 THz (microwaves to ultraviolet). An optical fiber can offer a transmission bandwidth in excess of 100 GHz.

Spectrum allocations are arrived at by an international agreement. The International Telecommunication Union (ITU) administers the present system of frequency allocations

### Propagation of electromagnetic wave

There are different ways which electromagnetic waves emitted by a transmitting antenna propagate through space and reach to the receiver.

### Ground wave

To radiate signals with high efficiency, the antennas should have a size comparable to the wavelength  $\lambda$  of the signal (at least  $\sim \lambda/4$ ).

At longer wavelengths (i.e., at lower frequencies), the antennas have large physical size and they are located on or very near to the ground. In standard AM broadcast, ground based vertical towers are generally used as transmitting antennas.

For such antennas, ground has a strong influence on the propagation of the signal. The mode of propagation is called surface wave propagation and the wave glides over the surface of the earth.

A wave induces current in the ground over which it passes and it is attenuated as a result of absorption of energy by the earth. The attenuation of surface waves increases very rapidly with increase in frequency.

The maximum range of coverage depends on the transmitted power and frequency (less than a few MHz).

### Space wave propagation

Radio waves propagated through the troposphere of the Earth are known as space waves. Troposphere is the portion of the Earth's atmosphere which extends upto 15 km from the surface of the Earth. Space wave usually consists of two components as shown in Fig

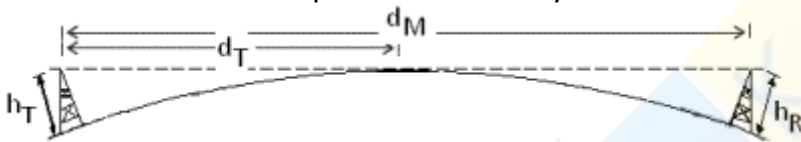

(i) A component which travels straight from the transmitter to the receiver. line-of-sight (LOS) communication

(ii) A component which reaches the receiver after reflection from the surface of the Earth.

Space wave propagation is particularly suitable for the waves having frequency above 30MHz.

If the transmitting antenna is at a height  $h_T$ , then you can show that the distance to the horizon  $d_T$  is given as  $d_T = \sqrt{2Rh_T}$ , where  $R$  is the radius of the earth (approximately 6400 km).  $d_T$  is also called the radio horizon of the transmitting antenna. With reference to Fig. the maximum line-of-sight distance  $d_M$  between the two antennas having heights  $h_T$  and  $h_R$  above the earth is given by

$$d_m = \sqrt{2Rh_T} + \sqrt{2Rh_R}$$

where  $h_R$  is the height of receiving antenna.

Area covered by transmission  $A = \pi(d_T)^2 = \pi(2h_TR)$

Television broadcast, microwave links and satellite communication are some examples of communication systems that use space wave mode of propagation

### Solved numerical

Q) What must be the height of the antenna of FM radio station so that people in a circular region of  $3140 \text{ km}^2$  can enjoy the programme of an FM radio station?  $R = 6400 \text{ km}$

Solution:

Area covered by transmission  $A = \pi(2h_TR)$

$$3140 = 3.14 \times 2 \times h_T \times 6400$$

$$h_T = 0.078125 \text{ km} = 78.125 \text{ m}$$

Q) A transmitting antenna at the top of a tower has a height of 50m and the height of the receiving antenna is 32m. What is the maximum distance between them for satisfactory communication is LOS mode? Give radius of earth  $R = 6400\text{km}$

Solution:

$$h_R = 32\text{m}, h_T = 50 \text{ m},$$

From formula

$$d_m = \sqrt{2Rh_T} + \sqrt{2Rh_R}$$

$$d_m = \sqrt{2 \times 6400 \times 10^3 \times 50} + \sqrt{2 \times 6400 \times 10^3 \times 32}$$

$$d_m = 25.29 \times 10^3 + 20.23 \times 10^3 = 45.5 \text{ km}$$

### Sky wave propagation

The propagation of radio waves ( frequency 2MHz to 30 MHz) is due to sky waves. The electromagnetic waves emitted by the transmitter, return to the earth after getting reflected by the ionosphere at a height of about 80 -300km. A receiver at large distance can receive these reflected waves. The ionosphere behaves like a mirror for these radio waves.

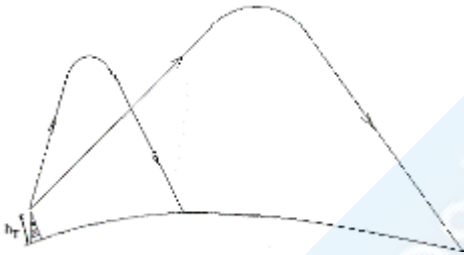

Ionosphere of earth atmosphere contains electrons anions produced due to radiation from sun. There are different layers at various heights, depending on the density of gas, intensity of radiation and selective ionization of gases by various radiation. Electron density of all layers are different. So the radio waves with different frequencies get reflected from the ionosphere of different height. Due to total internal reflection phenomenon waves can be received at far distance from the transmitter on the earth. Frequency from 2MHz to 30MHz are used above 30MHz frequency wave penetrate the ionosphere and cannot be reflected by ionosphere.

### Modulation and its necessity

Most of the signals of information have low frequency and they are not able to travel long distance in free space. Because of following factors

(1)Length of antenna: A transmitter converts audio frequency electrical signal into electromagnetic radiation through an antenna and radiates in the space

For effective transmission of electromagnetic radiation of audio signal, the minimum length of antenna must be  $\lambda/4$ . Where  $\lambda$  is the wavelength of the audio signal

If transmitted wavelength is 300 km whose frequency is about 1kHz then minimum length of antenna would be

$300/4 = 75$  km, which impractical as well as very costly

This shows that for effective transmission of high frequency signals, required antenna length is small and hence an antenna can be easily constructed.

(2) Power radiated from antenna: Transmitted power by an antenna of a given length is inversely proportional to the square of the wavelength  $\lambda$  i.e.  $P \propto 1/\lambda^2$ .

This indicates that an antenna can transmit short wavelength or high frequency radiation with more efficiency.

(3) Mixing up of signals from different transmitters: If there is more than one transmitter in a region and if these transmit the information using audio signals, then all such signals get mixed. It is not possible to separate information of one transmitter from the information of other transmitter. Such situation can be avoided if every transmitter is assigned different high frequencies for information.

## Modulation

The process of superposing low frequency audio signals on waves with high frequency is called modulation.

Here, low frequency signal is called the modulating and the high frequency wave, since it carries the information is called a carrier wave.

A sinusoidal carrier wave can be represented as  $c(t) = A_c \sin(\omega_c t + \phi)$

where  $c(t)$  is the signal strength (voltage or current),  $A_c$  is the amplitude,  $\omega_c (= 2\pi\nu_c)$  is the angular frequency and  $\phi$  is the initial phase of the carrier wave. During the process of modulation, any of the three parameters, viz  $A_c$ ,  $\omega_c$  and  $\phi$ , of the carrier wave can be controlled by the message or information signal.

This results in three types of modulation: (i) Amplitude modulation (AM), (ii) Frequency modulation (FM) and (iii) Phase modulation (PM) as shown in figure

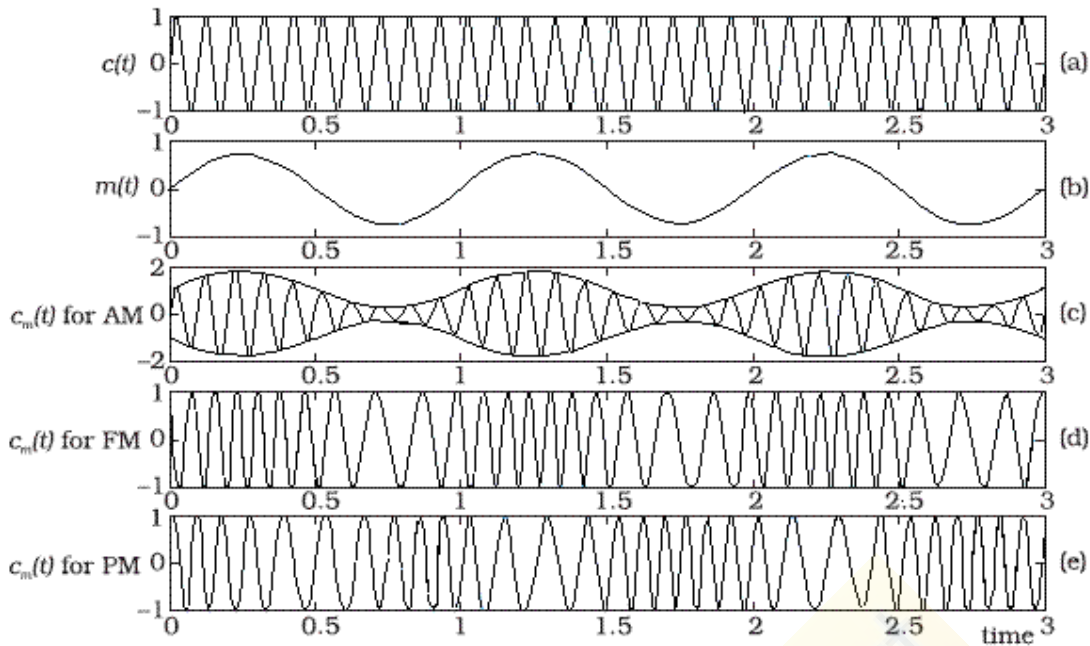

### Amplitude modulation

A modulation in which the amplitude of carrier wave  $C(t)$  is varied in accordance with the instantaneous value of the modulating wave is called amplitude modulation (AM). The frequency and initial phase remains constant

Let  $c(t) = A_c \sin \omega_c t$  represent carrier wave and  $m(t) = A_m \sin \omega_m t$  represent the message or the modulating signal where  $\omega_m = 2\pi f_m$  is the angular frequency of the message signal. Amplitude of carrier wave changes according to modulating signal but frequency and phase of the carrier wave remains constant thus

The modulated signal  $c_m(t)$  can be written as

$$c_m(t) = (A_c + A_m \sin \omega_m t) \sin \omega_c t$$

$$C_m(t) = A_c \left( 1 + \frac{A_m}{A_c} \sin \omega_m t \right) \sin \omega_c t$$

$$C_m(t) = A_c(1 + \mu \sin \omega_m t) \sin \omega_c t \text{ --- eq(1)}$$

Above equation is a mathematical form of AM wave

Here  $\mu = A_m/A_c$  is the *modulation index*; in practice,  $\mu$  is kept  $\leq 1$  to avoid distortion.

$$C_m(t) = A_c \sin \omega_c t + A_c \mu \sin \omega_m t \sin \omega_c t$$

Using the trigonometric relation  $\sin A \sin B = \frac{1}{2} (\cos(A - B) - \cos(A + B))$ , above equation can be wrote as

$$C_m(t) = A_c \sin \omega_c t + \frac{\mu A_c}{2} \cos(\omega_c - \omega_m)t - \frac{\mu A_c}{2} \cos(\omega_c + \omega_m)t$$

Here  $\omega_c - \omega_m$  and  $\omega_c + \omega_m$  are respectively called the lower side frequency band (LSB) and upper side frequency band (USB). The modulated signal now consists of the carrier wave of frequency  $\omega_c$  plus two sinusoidal waves each with a frequency slightly different from, known as side bands. The frequency spectrum of the amplitude modulated signal is shown in Fig

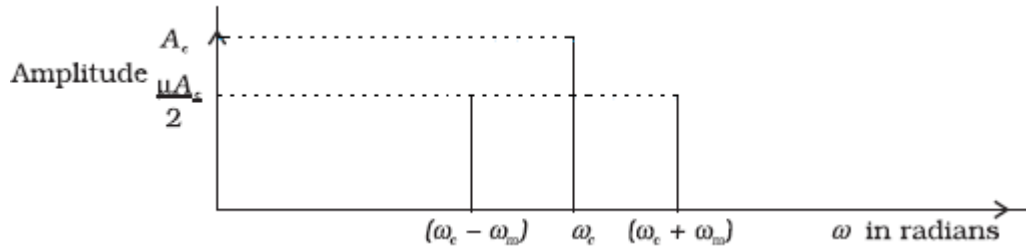

Amplitude of USB and LSB is  $\mu A_c/2$

From eq(1) When  $\sin\omega t = 1$  Amplitude modulated wave have maximum amplitude

$$A_{max} = A_c + A_m$$

When  $\sin\omega t = -1$ . Amplitude modulated wave have minimum amplitude

$$A_{min} = A_c - A_m$$

From above equations

$$A_c = \frac{A_{max} + A_{min}}{2} \text{ and } A_m = \frac{A_{max} - A_{min}}{2}$$

According to definition of modulation index

$$\mu = \frac{A_m}{A_c} = \frac{A_{max} - A_{min}}{A_{max} + A_{min}}$$

$$\mu(\%) = \frac{A_{max} - A_{min}}{A_{max} + A_{min}} \times 100$$

### Solved numerical

Q) A 10 MHz sinusoidal carrier wave of amplitude 10 mV is modulated by a 5 kHz sinusoidal audio signal wave of amplitude 6 mV. Find the frequency components of the resultant modulated wave and their amplitude.

Data: Frequency of the carrier =  $f_c = 10$  MHz

Frequency of the signal =  $f_s = 5$  kHz = 0.005 MHz

Amplitude of the carrier signal =  $E_c = 10$  mV

Amplitude of the audio signal =  $E_s = 6$  mV

Frequency components of modulated wave = ?

Amplitude of the components in the modulated wave = ?

Solution :

The modulated carrier wave contains the following frequencies :

(i) Original carrier wave of frequency =  $f_c = 10$  MHz

(ii) Upper side band frequency,  $f_c + f_s = 10 + 0.005 = 10.005$  MHz

(iii) Lower side band frequency  $f_c - f_s = 10 - 0.005 = 9.995$  MHz

The modulation factor is,

$$\mu = \frac{A_m}{A_c} = \frac{6}{10} = 0.6$$

$\therefore$  Amplitude of USB = Amplitude of LSB



$$\frac{\mu A_c}{2} = \frac{0.6 \times 10}{2} = 3mV$$

Q) The equation of AM wave is  $C = 100(1 + 0.6\sin 6280t) \sin 2\pi \times 10^6 t$ . Calculate  
 (i) Modulation Index (ii) Frequency of carrier wave (iii) frequency of modulating wave (iv)  
 frequency of LSB and USB

Solution:

Comparing given equation with standard equation

$$C_m(t) = A_c(1 + \mu \sin \omega_m t) \sin \omega_c t$$

We get (i) modulation index  $\mu = 0.6$

(ii) Frequency of carrier wave  $\omega_c = 2\pi \times 10^6$

$$\therefore 2\pi f_c = 2\pi \times 10^6$$

$$\therefore f_c = 10^6 \text{ Hz} = 1\text{MHz}$$

(iii) Frequency of modulating wave

$$\omega_m = 6280$$

$$\therefore 2\pi f_m = 6280$$

$$\therefore 2 \times 3.14 \times f_m = 6280$$

$$\therefore f_m = 1000 \text{ Hz} = 1\text{kHz}$$

(iv) frequency of LSB

$$f = f_c - f_m = 1\text{MHz} - 1\text{kHz} = 0.999 \text{ MHz}$$

frequency USB

$$f = f_c + f_m = 1\text{MHz} + 1\text{kHz} = 1.001 \text{ MHz}$$

### Production of amplitude modulated wave

Amplitude modulation can be produced by a variety of methods. A conceptually simple method is shown in the block diagram of Fig.

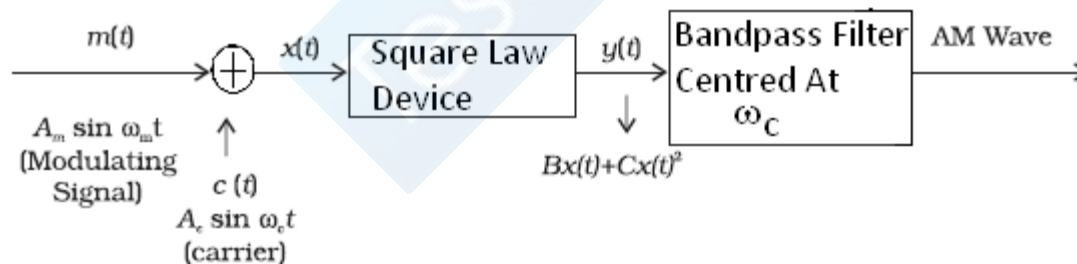

Here the modulating signal  $A_m \sin \omega_m t$  is added to the carrier signal  $A_c \sin \omega_c t$  to produce the signal  $x(t)$ . This signal  $x(t) = A_m \sin \omega_m t + A_c \sin \omega_c t$  is passed through a square law device which is a non-linear device which produces an output

$$y(t) = Bx(t) + Cx^2(t)$$

where  $B$  and  $C$  are constants. Thus,

$$y(t) = BA_m \sin \omega_m t + BA_c \sin \omega_c t + C[A_m^2 \sin^2 \omega_m t + A_c^2 \sin^2 \omega_c t + 2A_m A_c \sin \omega_c t \sin \omega_m t]$$

From trigonometry formula  $\sin^2 A = (1 - \cos 2A)/2$  we get

$$y(t) = BAm \sin \omega_m t + BA_c \sin \omega_c t + \frac{CA_m^2}{2} + A_c^2 - \frac{CA_m^2}{2} \cos 2\omega_m t - \frac{CA_c^2}{2} \cos 2\omega_c t + CA_m A_c \cos(\omega_c - \omega_m)t - CA_m A_c \cos(\omega_c + \omega_m)t$$

In above equation dc term is  $C/2(A_m^2 + A_c^2)$  and sinusoids of frequencies  $\omega_m, 2\omega_m, \omega_c, 2\omega_c, \omega_c - \omega_m,$  and  $\omega_c + \omega_m$  this signal passes through a band filters which rejects dc and the frequencies of  $\omega_m, 2\omega_m, 2\omega_c$  and retains frequencies  $\omega_c, \omega_c - \omega_m,$  and  $\omega_c + \omega_m$ . the out put therefore is amplitude modulated waves

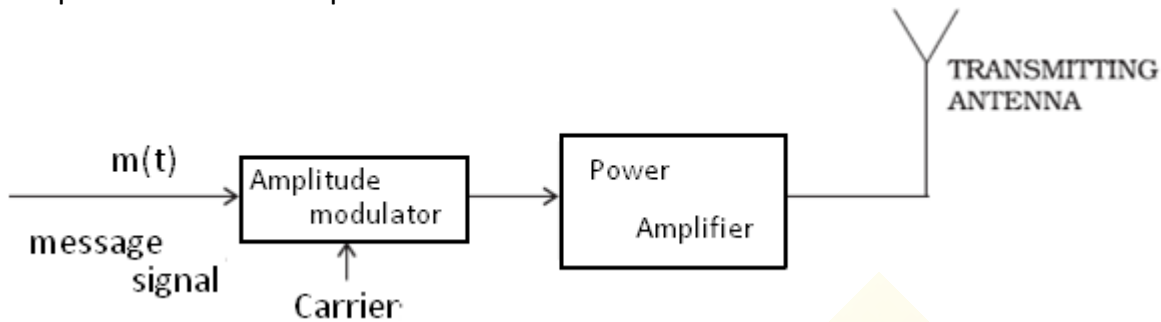

Modulated signals cannot be transmitted as such. The modulator is followed by a power amplifier which provides the necessary power and then modulated signals is forwarded to an antenna of appropriate size for radiation as shown in figure

### Detection of amplitude modulated wave

The transmitted message gets attenuated in propagating through the channel. The receiving antenna is therefore to be followed by an amplifier and a detector.

In addition, to facilitate further processing, the carrier frequency is usually changed to a lower frequency by what is called an *intermediate frequency (IF) stage* preceding the detection.

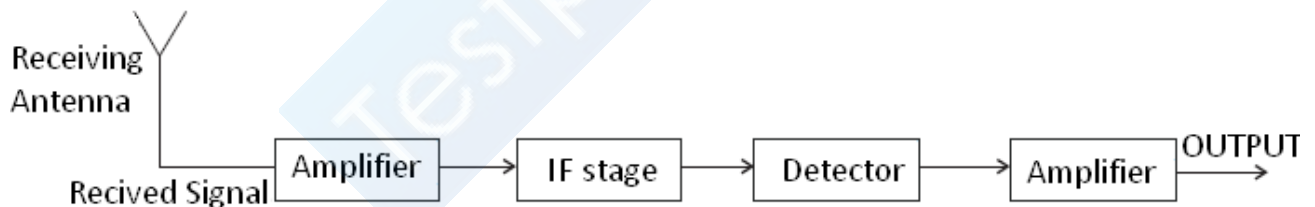

The detected signal may not be strong enough to be made use of and hence is required to be amplified. A block diagram of a typical receiver is shown in Detection is the process of recovering the modulating signal from the modulated carrier wave.

We know that the modulated carrier wave contains the frequencies  $\omega_c$  and  $\omega_c \pm \omega_m$ . In order to obtain the original message signal  $m(t)$  of angular frequency  $\omega_m$ , a simple method is shown in the form of a block diagram in Fig.

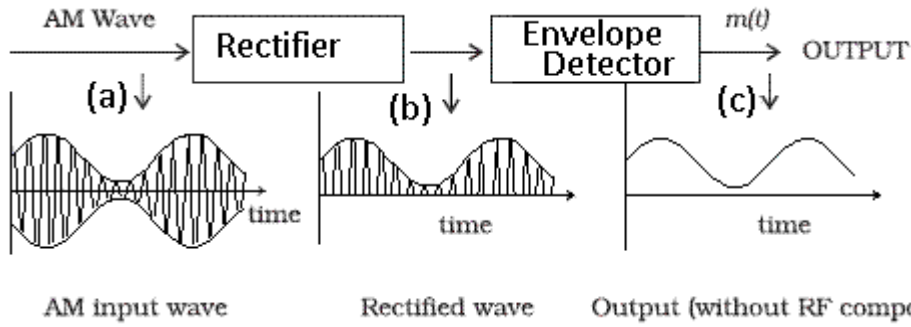

The modulated signal of the form given in (a) of fig. is passed through a rectifier to produce the output shown in (b).

This envelope of signal (b) is the message signal. In order to retrieve  $m(t)$ , the signal is passed through an envelope detector (which may consist of a simple RC circuit).

Testprep Kart