

SURFACE TENSION & VISCOSITY

SURFACE TENSION

Intermolecular forces

The force between two molecules of a substance is called intermolecular force. This intermolecular force is basically electric in nature. When the distance between two molecules is greater, the distribution of charges is such that the mean distance between opposite charges in the molecule is slightly less than the distance between their like charges. So a force of attraction exists. When the intermolecular distance is less, there is overlapping of the electron clouds of the molecules resulting in a strong repulsive force. The intermolecular forces are of two types. They are (i) cohesive force and (ii) adhesive force.

Cohesive force

Cohesive force is the force of attraction between the molecules of the same substance. This cohesive force is very strong in solids, weak in liquids and extremely weak in gases.

Adhesive force

Adhesive force is the force of attraction between the molecules of two different substances. For example due to the adhesive force, ink sticks to paper while writing. Fevicol, gum etc exhibit strong adhesive property.

Water wets glass because the cohesive force between water molecules is less than the adhesive force between water and glass molecules. Whereas, mercury does not wet glass because the cohesive force between mercury molecules is greater than the adhesive force between mercury and glass molecules.

Molecular range and sphere of influence

Molecular range is the maximum distance upto which a molecule can exert force of attraction on another molecule. It is of the order of 10^{-9} m for solids and liquids.

Sphere of influence is a sphere drawn around a particular molecule as centre and molecular range as radius. The central molecule exerts a force of attraction on all the molecules lying within the sphere of influence.

Surface tension of a liquid

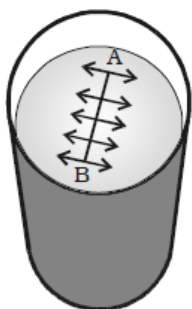

Surface tension is the property of the free surface of a liquid at rest to behave like a stretched membrane in order to acquire minimum surface area.

Imagine a line AB in the free surface of a liquid at rest (Fig. 5.20). The force of surface tension is measured as the force acting per unit length on either side of this imaginary line AB. The force is perpendicular to the line and tangential to the liquid surface. If F is the force acting on the length l of the line AB, then surface tension is given by

$$T = \frac{F}{L}$$

Surface tension is defined as the force per unit length acting perpendicular on an imaginary line drawn on the liquid surface, tending to pull the surface apart along the line. Its unit is N m^{-1} and dimensional formula is MT^{-2} .

It depends on temperature. The surface tension of all liquids decreases linearly with temperature

It is a scalar quantity and become zero at critical temperature

Molecular theory of surface tension

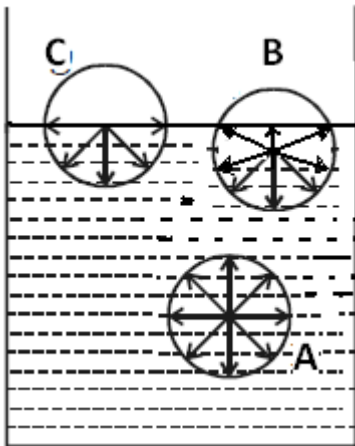

The surface tension of liquid arises out of the attraction of its molecules. Molecules of fluid (liquid and gas) attract one another with a force. If any other molecule is within the sphere of influence of first molecule it will experience a force of attraction

Consider three molecules A, B, C having their spheres of influence as shown in the figure. The sphere of influence of A is well inside the liquid, that of B partly outside and that of C exactly half of total

Molecules like A do not experience any resultant force, as they are attracted equally in all directions. Molecules like B or C will experience a resultant force directed inward. Thus the molecules will inside the liquid will have only kinetic energy but the molecule near surface will have kinetic as well as potential energy which is equal o the work done in placing them near the surface against the force of attraction directed inward

Surface energy

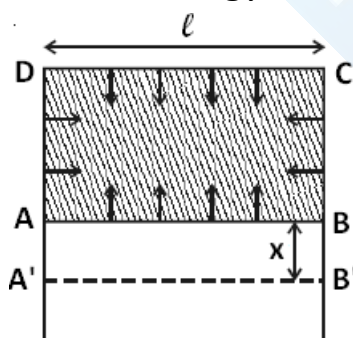

Any Strained body possesses potential energy, which is equal to the work done in bringing it to the present state from its initial unstained state. The surface of liquid is also a strained system and hence the surface of a liquid also has potential energy, which is equal to the work done increasing the surface. This energy per unit area of the surface is called surface energy

To derive an expression for surface energy consider a wire frame equipped with a sliding wire AB as shown in figure. A film

of soap solution is formed across ABCD of the frame. The side AB is pulled to the left due to surface tension. To keep the wire in position a force F has to be applied to the right. If T is the surface tension and l is the length of AB, then the force due to surface tension over AB is $2lT$ to the left because the film has two surfaces (upper and lower)

Since the film is in equilibrium $F = 2lT$

Now, if the wire AB is pulled down, energy will flow from the agent to the film and this energy is stored as potential energy of the surface created just now. Let the wire be pulled slowly through x.

Then the work done = energy added to the film from above agent

$$W = Fx = 2ITx$$

Potential energy per unit area (surface energy) of the film

$$U = \frac{2ITx}{2lx} = T$$

$$T = \frac{W}{\text{area}}$$

Thus surface energy numerically equal to its surface tension

Its unit is Joule per square metre (Jm^{-2})

Solved Numerical

Q) Calculate the work done in blowing a soap bubble of radius 10cm, surface tension being 0.08 Nm^{-1} . What additional work will be done in further blowing it so that its radius is doubled?

Solution

In case of a soap bubble, there are two free surfaces

Surface tension = Work done per unit area

\therefore Work done in blowing a soap bubble of radius R is given by = Surface tension \times Area

$$W = T \times (2 \times 4\pi R^2)$$

$$W = (0.06) \times (8 \times 3.14 \times 0.1^2)$$

$$W = 1.51 \text{ J}$$

Similarly, work done in forming a bubble of radius 0.2 m is

$$W' = (0.06) \times (8 \times 3.14 \times 0.2^2) = 60.3 \text{ J}$$

Additional work done in doubling the radius of the bubble is given by

$$W' - W = 60.3 - 1.51 = 5.42 \text{ J}$$

Q) A mercury drop of radius 1cm is sprayed into 10^6 droplets of equal size. Calculate the energy expended if surface tension of mercury is $35 \times 10^{-3} \text{ N/m}$

Solution

Since total volume of 10^6 droplet has remains same

If radius small droplet is r' and big drop is r then $r = (10^6)^{1/3} r'$

$$1 = 10^2 r' \text{ or } r' = 0.01 \text{ cm} = 10^{-4} \text{ m}$$

Since surface area is increased energy should be supplied to make small small drops

$$\text{Total energy of small droplet} = [T (4\pi r'^2)] 10^6$$

$$\text{Total energy of big droplet} = [T(4\pi r^2)]$$

Spending of energy = Total energy of small droplets - Total energy of big droplet

$$\text{Spending of energy} = [T (4\pi r'^2)] 10^6 - [T(4\pi r^2)]$$

$$\text{Spending of energy} = T \times 4\pi [10^6 \times r'^2 - r^2]$$

$$\text{Spending of energy} = 35 \times 10^{-3} \times 4 \times 3.14 [10^6 \times (10^{-4})^2 - (10^{-2})^2]$$

$$\text{Spending of energy} = 0.44 [10^{-2} - 10^{-4}]$$

$$\text{Spending of energy} = 4.356 \times 10^{-3} \text{ J}$$

Angle of contact

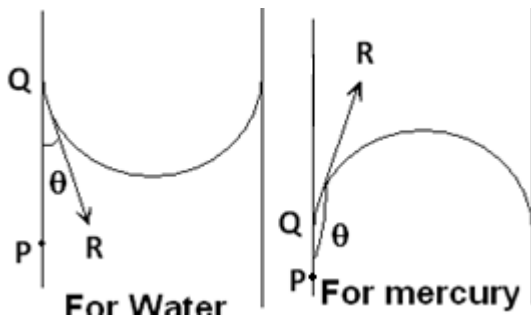

When the free surface of a liquid comes in contact with a solid, it becomes curved at the point of contact. *The angle between the tangent to the liquid surface at the point of contact of the liquid with the solid and the solid surface inside the liquid is called angle of contact.* In Fig., QR is the tangent drawn at the point of contact Q. The angle PQR is called the angle of contact. When a liquid has

concave meniscus, the angle of contact is acute. When it has a convex meniscus, the angle of contact is obtuse. The angle of contact depends on the nature of liquid and solid in contact. For water and glass, θ lies between 8° and 18° . For pure water and clean glass, it is very small and hence it is taken as zero. The angle of contact of mercury with glass is 138° .

Pressure difference across a liquid surface

If the free surface of a liquid is plane, then the surface tension acts horizontally (Fig. a). It has no component perpendicular to the horizontal surface. As a result, there is no pressure difference between the liquid side and the vapour side.

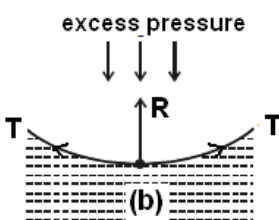
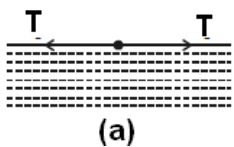

If the surface of the liquid is concave (Fig. b), then the resultant force R due to surface tension on a molecule on the surface act vertically upwards. To balance this, an excess of pressure acting downward on the concave side is necessary.

On the other hand if the surface is convex (Fig.c), the resultant R acts downward and there must be an excess of pressure on the concave side acting in the upward direction.

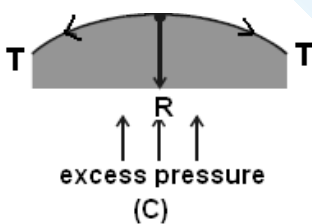

Thus, there is always an excess of pressure on the concave side of a curved liquid surface over the pressure on its convex side due to surface tension.

Excess pressure

The pressure inside a liquid drop or a soap bubble must be in excess of the pressure outside the bubble or drop because without such pressure difference a drop or a bubble cannot be in state of equilibrium. Due to surface tension the drop or bubble has got the tendency to contract and disappear altogether.

To balance this, there must be an excess of pressure inside the bubble.

To obtain a relation between the excess pressure and the surface tension, consider a water drop of radius r and surface tension T ,

The excess of pressure P inside the drop provides a force acting outwards perpendicular to the surface, to balance the resultant force due to surface tension.

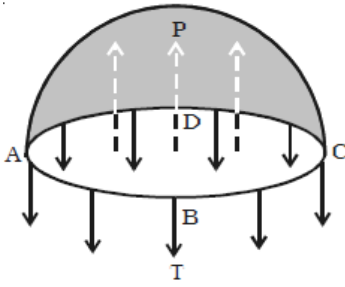

Imagine the drop to be divided into two equal halves.

Considering the equilibrium of the upper hemisphere of the drop, the upward force on the plane face ABCD due to excess pressure P is $P \pi r^2$

If T is the surface tension of the liquid, the force due to surface tension acting downward along the circumference of the circle ABCD is $T 2\pi r$.

At equilibrium, $P\pi r^2 = T 2\pi r$

$$P = \frac{2T}{r}$$

Here P is excess pressure $P = P_i - P_o$

$$P_i - P_o = \frac{2T}{r}$$

Excess pressure inside a soap bubble

A soap bubble has two liquid surfaces in contact with air, one inside the bubble and the other outside the bubble. Therefore the force due to surface tension = $2 \times 2\pi rT$

\therefore At equilibrium, $P \pi r^2 = 2 \times 2\pi rT$

$$P = \frac{4T}{r}$$

Thus the excess of pressure inside a drop is inversely proportional to its radius the pressure needed to form a very small bubble is high. This explains why one needs to blow hard to start a balloon growing. Once the balloon has grown, less air pressure is needed to make it expand more.

Solved Numerical

Q) An air bubble of radius R is formed on a narrow tube having a radius r where $R \gg r$. Air of density ρ is blown inside the tube with velocity V . The air molecules collide perpendicularly with the wall of bubble and stop. Find the radius at which the bubble separates from the tube. Take surface tension of bulb as T

Solution:

Air molecules collides at stops thus force exerted on the soap bubble

Mass of air = Volume $\times \rho$

Volume of air = velocity of air \times area of hole = $v (\pi r^2)$

Mass of air = $v \rho (\pi r^2)$

Force exerted by the air = change in momentum of air molecules

Force due to air molecule = $(v \rho \pi r^2) v = \rho \pi r^2 v^2$

Pressure of blown air in side the bubble = ρv^2

Now Force due to surface tension of bubble of radius R

Pressure difference in bubble = $4T/R$

Bubble gets separated when pressure difference in bubble = pressure of blown air

$$\frac{4T}{R} = \rho v^2$$

$$R = \frac{4T}{\rho v^2}$$

Q) Two spherical soap bubbles coalesce to form a single bubble. If V is the consequent change in volume of the contained air and S the change in the total surface area, show that $3PV + 4ST = 0$, where T is the surface tension of the soap bubble and P the atmospheric pressure

Solution:

$$P_1 = P + \frac{4T}{r_1} ; P_2 = P + \frac{4T}{r_2}$$

Since the total number of moles remains same

$$N_1 + n_2 = n$$

$$P_1 V_1 + P_2 V_2 = P_3 V_3$$

$$\left(P + \frac{4T}{r_1}\right) \left(\frac{4}{3} \pi r_1^3\right) + \left(P + \frac{4T}{r_2}\right) \left(\frac{4}{3} \pi r_2^3\right) = \left(P + \frac{4T}{r}\right) \left(\frac{4}{3} \pi r^3\right)$$

$$\left(P + \frac{4T}{r_1}\right) (r_1^3) + \left(P + \frac{4T}{r_2}\right) (r_2^3) = \left(P + \frac{4T}{r}\right) (r^3)$$

$$Pr_1^3 + 4Tr_1^2 + Pr_2^3 + 4Tr_2^2 = Pr^3 + 4Tr^2$$

$$4Tr_1^2 + 4Tr_2^2 - 4Tr^2 = Pr^3 - Pr_1^3 - Pr_2^3$$

$$4T(r_1^2 + r_2^2 - r^2) = P(r^3 - r_1^3 - r_2^3)$$

$$\frac{4}{3} \pi 4T(r_1^2 + r_2^2 - r^2) = \frac{4}{3} \pi P(r^3 - r_1^3 - r_2^3)$$

$$4T(S_1 + S_2 - S_3) = 3P(V_3 - V_1 - V_2)$$

$$4TS = -3PV$$

Negative V because $V_3 < V_1 + V_2$

$$4TS + 3PV = 0$$

Surface tension by capillary rise method

Let us consider a capillary tube of uniform bore dipped vertically in a beaker containing water. Due to surface tension, water rises to a height h in the capillary tube as shown in Fig.. The surface tension T of the water acts inwards and the reaction of the tube R outwards. R is equal to T in magnitude but opposite in direction. This reaction R can be resolved into two rectangular components.

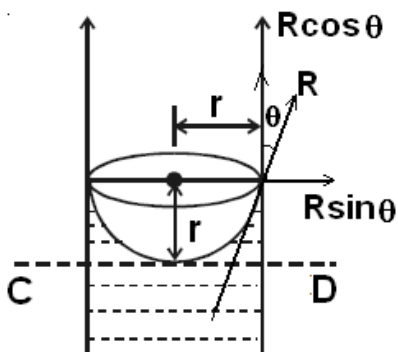

(i) Horizontal component $R \sin \theta$ acting radially outwards

(ii) Vertical component $R \cos \theta$ acting upwards.

The horizontal component acting all along the circumference of the tube cancel each other whereas the vertical component balances the weight of water column in the tube.

Total upward force = $R \cos \theta \times$ circumference of the tube

$$F = 2\pi r R \cos \theta \text{ or } F = 2\pi r T \cos \theta \dots(1)$$

$$[\because R = T]$$

This upward force is responsible for the capillary rise. As the water column is in equilibrium, this force acting upwards is equal to weight of the water column acting downwards.

$$(i.e) F = W \dots(2)$$

Now, volume of water in the tube is assumed to be made up of

(i) a cylindrical water column of height h and (ii) water in the meniscus above the plane CD.

Volume of cylindrical water column = $\pi r^2 h$

Volume of water in the meniscus

= (Volume of cylinder of height r and radius r) – (Volume of hemisphere)

\therefore Volume of water in the meniscus =

$$\pi r^2 \times r - \frac{2}{3} \pi r^3 = \frac{1}{3} \pi r^3$$

\therefore Total volume of water in the tube

$$\pi r^2 h + \frac{1}{3} \pi r^3 = \pi r^2 \left(h + \frac{r}{3} \right)$$

If ρ is the density of water, then weight of water in the tube is

$$W = \pi r^2 \left(h + \frac{r}{3} \right) \rho g \quad \dots \text{eq(3)}$$

Substituting (1) and (3) in (2),

$$\pi r^2 \left(h + \frac{r}{3} \right) \rho g = 2\pi r T \cos \theta$$

$$T = \frac{\pi r^2 \left(h + \frac{r}{3} \right) \rho g}{2\pi r \cos \theta}$$

Since r is very small, $r/3$ can be neglected compared to h .

$$T = \frac{hr\rho g}{2\cos\theta}$$

For water θ is very small $\cos\theta = 1$

$$T = \frac{hr\rho g}{2}$$

Solved Numerical

Q) An U-tube with limbs of diameter 5mm and 2mm contains water of surface tension 7×10^{-2} N/m, angle of contact zero and density 1×10^3 kg/m³. Find the difference in levels ($g = 10$ m/s²)

Solution: If the menisci are spherical, they will be hemispheres Since angle of contact is zero, their radii will then equal to radii of the limbs. The pressure on the concave side of

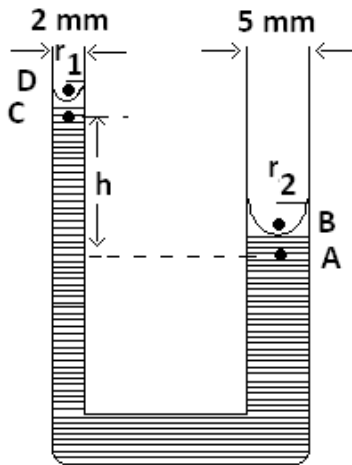

each surface exceeds that on the convex side by $2T/r$, where T is surface tension and r is the radius of the limb concerned

Now $r_1 = 2.5 \text{ mm} = 2.5 \times 10^{-3} \text{ m}$ and $r_2 = 1 \text{ mm} = 10^{-3} \text{ m}$

Hence

$$P_B - P_A = \frac{2T}{r_2} = \frac{2 \times 7 \times 10^{-2}}{2.5 \times 10^{-3}} = 56 \text{ Pa}$$

$$P_A = P_B + 56 = P + 56$$

Similarly

$$P_D - P_C = \frac{2T}{r_1} = \frac{2 \times 7 \times 10^{-2}}{10^{-3}} = 140 \text{ Pa}$$

$$P_D = P_C + 140 = P + 140$$

Since $P_D = P_B = P$

$$\therefore P_A - P_C = (P + 56) - (P + 140)$$

$$P_A - P_C = 84 \text{ Pa}$$

But $P_A = P_C + h\rho g$

$$h\rho g = 84 \text{ Pa}$$

$$\therefore h = \frac{84}{10^3 \times 10} = 8.4 \text{ mm}$$

Q) A mercury barometer has a glass tube with an inside diameter equal to 4mm. Since the contact angle of mercury with glass is 140° , capillarity depresses the column. How many millimeters of mercury must be added to the reading to correct for capillarity (Assume surface tension of mercury $T = 0.545 \text{ N/m}$, density of mercury $= 13.6 \times 10^3$)

Solution:

The height difference due to capillarity give by

$$h = \frac{2T \cos \theta}{r \rho g}$$

$$h = \frac{2 \times 0.545 \times \cos 140}{(2 \times 10^{-3})(13.6 \times 10^3)(9.8)} = -0.0031 \text{ m}$$

Therefore 3.1mm must be added to the barometer reading

Factors affecting surface tension

Impurities present in a liquid appreciably affect surface tension. A highly soluble substance like salt increases the surface tension whereas sparingly soluble substances like soap decreases the surface tension.

The surface tension decreases with rise in temperature. The temperature at which the surface tension of a liquid becomes zero is called critical temperature of the liquid.

Applications of surface tension

(i) During stormy weather, oil is poured into the sea around the ship. As the surface tension of oil is less than that of water, it spreads on water surface. Due to the decrease in surface tension, the velocity of the waves decreases. This reduces the wrath of the waves on the ship.

(ii) Lubricating oils spread easily to all parts because of their low surface tension.

(iii) Dirty clothes cannot be washed with water unless some detergent is added to water.

When detergent is added to water, one end of the hairpin shaped molecules of the detergent get attracted to water and the other end, to molecules of the dirt. Thus the dirt is suspended surrounded by detergent molecules and this can be easily removed. This detergent action is due to the reduction of surface tension of water when soap or detergent is added to water.

(iv) Cotton dresses are preferred in summer because cotton dresses have fine pores which act as capillaries for the sweat.

VISCOSITY

If we pour equal amounts of water and castor oil in two identical funnels. It is observed that water flows out of the funnel very quickly whereas the flow of castor oil is very slow. This is because of the frictional force acting within the liquid. This force offered by the adjacent liquid layers is known as viscous force and the phenomenon is called viscosity. *Viscosity is the property of the fluid by virtue of which it opposes relative motion between its different layers. Both liquids and gases exhibit viscosity but liquids are much more viscous than gases.*

Co-efficient of viscosity

Consider the slow and steady flow of a fluid over a fixed horizontal surface as shown in the Fig. Let v be the velocity of thin layer of liquid at a distance x from the fixed solid surface.



Then according to Newton, the viscous force acting tangentially to the layer is proportional to the area of the layer and the velocity gradient at the layer. If F is the viscous force on the layer then ,
 $F \propto A$, where A is the area of the layer and

$$F \propto - \frac{\Delta v}{\Delta x}$$

The negative sign is put to account for the fact that the viscous force is opposite to the direction of motion Thus

$$F = -\eta A \frac{dv}{dx}$$

Where η is a constant depending upon the nature of the liquid and is called the coefficient of viscosity and

$$\text{velocity gradient} = \frac{dv}{dx}$$

If $A = 1$ and $dv/dx = 1$. We have $F = -\eta$

Thus the coefficient of viscosity of a liquid may be defined as the viscous force per unit area of the layer where velocity gradient is unity

The coefficient of viscosity has the dimension $[ML^{-1}T^{-1}]$ and its unit is Newton second per square metre (Nsm^{-2}) or kilogram per metre per second ($kgm^{-1}s^{-1}$). In CGS, the unit of viscosity is Poise, 1kilogram per metre per second = 10 Poise

Stroke's Law

When a solid moves through a viscous medium, its motion is opposed by a viscous force depending on the velocity and shape and size of the body. The energy of the body is continuously decreases in overcoming the viscous resistance of the medium. This is why cars, aeroplanes etc are shaped streamline to minimize the viscous resistance on them. The viscous drag on a spherical body of radius r , moving with velocity v , in a viscous medium of viscosity η is given by

$$F_{\text{viscous}} = 6\pi\eta rv$$

This relation is called **Stoke's law**

This law can be deduced by the method of dimensions.

Terminal Velocity

Let the body be driven by a constant force. In the beginning velocity $v = 0$ and acceleration 'a' is max so the body experiences small viscous force. With increase in speed viscous force goes on increasing till resultant force acting on the body becomes zero, and body moves with constant speed, this speed is known as terminal velocity

Consider the downward movement of a spherical body through a viscous medium such as a ball falling through a viscous medium as a ball falling through a liquid. If r is the radius of the body, ρ the density of the material of the body and ρ_0 is the density of the liquid, then

(i) The weight of the body down ward force

$$\frac{4}{3}\pi r^3 \rho g$$

(ii) The buoyancy of the body upward force

$$\frac{4}{3}\pi r^3 \rho_0 g$$

Net down ward force

$$\frac{4}{3}\pi r^3 (\rho - \rho_0) g$$

If v is the terminal velocity of the body, then viscous force $F_{\text{viscous}} = 6\pi\eta rv$

When acceleration becomes zero

upward viscous force = resultant down ward force

$$6\pi\eta rv = \frac{4}{3}\pi r^3 (\rho - \rho_0) g$$

$$v = \frac{2r^2 g (\rho - \rho_0)}{9\eta}$$

Solved Numerical

Q) A steel ball of diameter $d = 3.0\text{mm}$ starts sinking with zero initial velocity in oil whose viscosity is 0.9P . How soon after the beginning of motion will the velocity of the ball differ from the steady state velocity by $n = 1.0\%$? Density of steel = $7.8 \times 10^3 \text{ kg/m}^3$

Solution: Initial acceleration is maximum and becomes zero thus acceleration is not constant:

$$\text{Viscosity} = 0.9\text{P} = 0.09 \text{ kgm}^{-1}\text{s}^{-1}$$

Net force on ball = $W - F_B - F_v$

F_B = Buoyant force up ward F_v = viscous force upwards , W = weight of ball down wards

Force = ma thus

$$m \frac{dv}{dt} = mg - F_B - 6\eta\pi r v$$

Let $A = mg - F_B$ is constant and $B = 6\eta\pi r$ is another constant

$$m \frac{dv}{dt} = A - Bv$$

$$m \frac{dv}{(A - Bv)} = dt$$

Velocity after time t differs from the steady state velocity by $n = 1.0\%$

$v = (1-n)v'$ here v' is terminal velocity

$$m \int_0^{(1-n)v'} \frac{dv}{(A - Bv)} = \int_0^t dt$$

$$-\frac{m}{B} \ln \left[\frac{A - B(1-n)v'}{A} \right] = t$$

At steady state net force is zero

$$A - Bv' = 0 \quad \therefore \quad v_s = A/B$$

$$t = -\frac{m}{B} \ln \left[\frac{A - B(1-n)\frac{A}{B}}{A} \right]$$

$$t = -\frac{m}{B} \ln n$$

$$t = -\frac{m}{6\eta\pi r} \ln n$$

$$t = -\frac{\frac{4}{3}\pi r^3 \rho}{6\eta\pi r} \ln n$$

$$t = -\frac{2r^2 \rho}{9\eta} \ln n$$

$$t = -\frac{2\left(\frac{3 \times 10^{-3}}{2}\right)^2 7.8 \times 10^3}{9(0.09)} \ln(0.01)$$

$t = 0.2 \text{ sec}$

Q) As shown in figure laminar flow is obtained in a tube of internal radius r and length l .

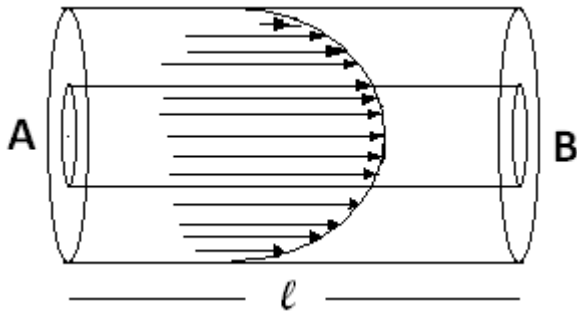

To maintain such flow, the force balancing the viscous force obtained by producing the pressure difference (P) across the ends of the tube. Derive the equation of velocity of a layer situated at distance ' x ' from the axis of the tube

Solution

Consider a cylindrical layer of radius x as shown in figure. The force acting on it are as follows

- (1) At face A let pressure be P_1 Thus force $F_1 = \pi x^2 P_1$
- (2) At face B let pressure be P_2 ($< P_1$) Thus force $F_2 = \pi x^2 P_2$ is against F_1
- (3) Viscous force $F_3 = \eta A \left(-\frac{dv}{dx}\right)$

A is curved area of cylinder of radius x , thus $A = 2\pi x l$

Negative sign indicates as we go from axis of cylinder to walls of cylinder velocity decreases

Viscous force F_3

$$F_3 = -\eta(2\pi x l) \frac{dv}{dx}$$

For the motion of the cylinder layer with a constant velocity

$$F_3 = F_1 - F_2$$

$$-\eta(2\pi x l) \frac{dv}{dx} = \pi x^2 P_1 - \pi x^2 P_2$$

$$-\eta(2\pi x l) \frac{dv}{dx} = \pi x^2 (P_1 - P_2)$$

$$-\eta(2\pi x l) \frac{dv}{dx} = \pi x^2 (P) \quad [\because P_1 - P_2 = P]$$

$$-dv = \frac{P}{2\eta l} x dx$$

At $x = r, v = 0$ and at $x = x, v = v$, so integrating the above equation in these limits we get

$$-\int_v^0 dv = \int_x^r \frac{P}{2\eta l} x dx$$

$$-[v]_v^0 = \frac{P}{4\eta l} [x^2]_x^r$$

$$-[0 - v] = \frac{P}{4\eta l} [r^2 - x^2]$$

$$v = \frac{P}{4\eta l} (r^2 - x^2)$$

If we want to find the volume of liquid flowing through the tube in one second

Then velocity at axis $x = 0$

$$v = \frac{Pr^2}{4\eta l}$$

At the wall ($x = r$) velocity is zero

∴ Average velocity

$$\langle v \rangle = \frac{Pr^2}{8\eta l}$$

Now volume of liquid = (average velocity) (Area of cross-section)

$$V = \frac{Pr^2}{8\eta l} (\pi r^2)$$

$$V = \frac{P\pi r^2}{8\eta l}$$

Above equation is called Poiseuille's Law